

FITTINGS AND SPECIALS

Pipeline projects often require a complicated geometry. The adaptability of Concrete Pressure Pipe with standard and custom-designed special fittings gives practical solutions to the piping system designer. Most configurations can be addressed, whether used for water intake, plant piping, transmission and distribution mains, sewer force mains, or sewer outfall projects.

Special fittings are designed and manufactured in accordance with the AWWA standards and the AWWA M9 Manual in diameters from 10 inches to 144 inches. Larger sizes have been manufactured based on the concepts presented in the standards and the M9 Manual.



Concrete Pressure Pipe fittings and specials meet complex demands of piping systems designers.

DESIGN CONSIDERATIONS

Concrete Pressure Pipe fittings are designed to meet the same pressure and loading conditions as the pipes adjacent to them, including both internal pressure as well as external load capacities. Fittings are fabricated from welded steel sheet or plate with a minimum thickness of 0.1345 in. (10 Ga.), with steel joint rings welded to the ends. They are then lined and coated with cement mortar or concrete. As with the pipe itself, this combination of materials results in efficient utilization of the tensile strength of steel and the compressive strength and corrosion inhibiting properties of concrete and mortar.

Internal pressure is resisted by the steel cylinder alone. The required steel thickness is calculated using the "Hoop Stress" formula. Depending on the size and configuration, outlets in pipe or fittings are reinforced by replacing the area of steel removed from the wall with either wrappers, saddles, collars, or crotch plates. External load carrying capacity of a fitting is calculated using semirigid pipe theory. Spangler's equation is used, limiting the horizontal or vertical deflection to $D^2/4000$ or $0.02D$ (whichever is less), where D is the nominal pipe diameter in inches. As an example, for a 42" diameter pipe, this results in a deflection of approximately 1 percent.



Concrete Pressure Pipe can be furnished with a variety of joint configurations.

Standard Joints

The standard Concrete Pressure Pipe joint is a steel bell and spigot with rubber O-ring gasket.

Testable Double Gasket Joints

A double gasket joint may be used when water pressure testing of the pipeline is not practical, or when it becomes crucial to test each joint as the pipe is installed. The installer can air-test the joint immediately to verify the gasket seal.

Restrained Joints

Concrete Pressure Pipe is available with restrained joints to avoid the need to construct thrust blocks during pipeline installation. Different types of restrained joints are available within the industry.

Welded Joints

There are two systems for welding the joints of Concrete Pressure Pipe:

- **Standard** – Regular bell and spigot joints can be welded either from the outside or inside. Due to limited working space in small diameter pipe, welding from the inside is seldom performed on pipe with a diameter of less than 36 inches.
- **Split Sleeve** – A split sleeve can be welded to plain steel ends. This system is mostly used for closures. Welded joints and split sleeves provide some flexibility in the adjustment of fittings on site. On smaller size pipe, a flexible welded joint is also available.

Bends

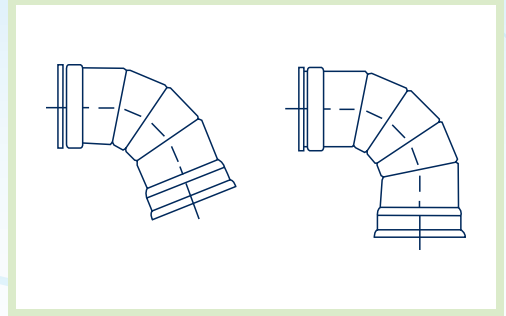

Tees

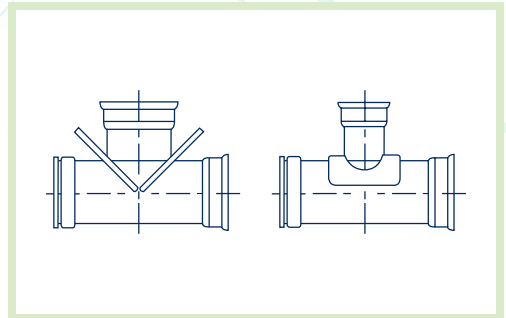

Eccentric and Concentric Reducers

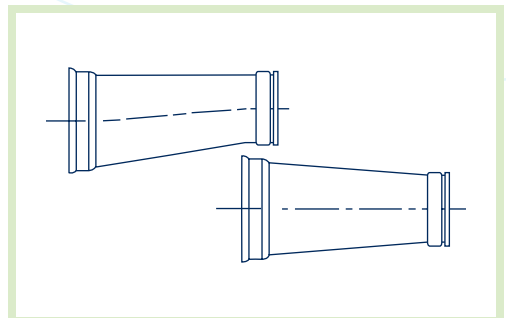

Wyes

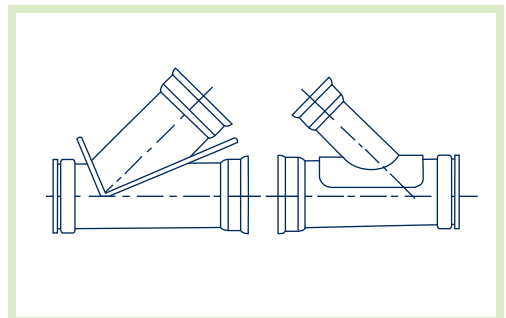

Internal Bulkhead Test Fitting and Wall Fittings

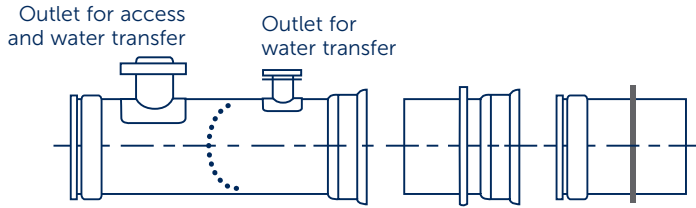

Plain Steel Ends

When a Concrete Pressure Pipe fitting connects to another type of pipe or structure, a plain steel end of the required outside diameter can be supplied.

Flanges

Flanges for any class or any drilling pattern can be installed on a Concrete Pressure Pipe fitting. The most common flange specification for the waterworks industry is AWWA Standard C207.

Others

Concrete Pressure Pipe fittings can connect to most other pipe materials using adapters available from the Concrete Pressure Pipe manufacturer. Any machined special end can be supplied to fit with couplings, whether they are plain, grooved, or shouldered.

Outlets

Small outlets serve many purposes, such as service connections and air release valves. Threaded outlets (3/4" to 3" dia.) can be installed on a straight pipe or fitting. Larger size outlets can be fabricated at required locations on straight pipe or fittings with any of the pipe ends described earlier.

An interesting feature of Concrete Pressure Pipe fittings is the availability of fabricated outlets at required angles, thus eliminating the need for additional separate fittings and allowing for outlets tangent to the pipe for drain and blow-off purposes.

Bulkheads

Dished and flat bulkheads are available with outlets for filling, draining, and air relief. Internal bulkheads are also available in sizes where access for removal is available. They are useful for isolating a section of pipeline during initial testing.

Bifurcations

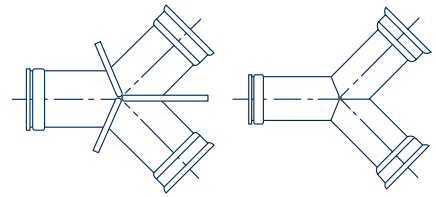

Adapters

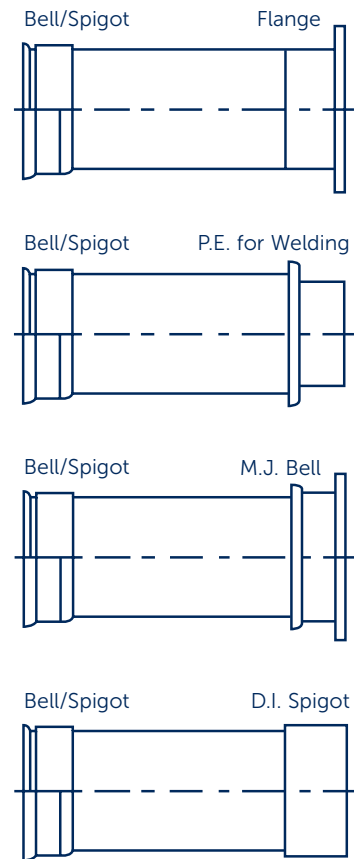

Closure Sections

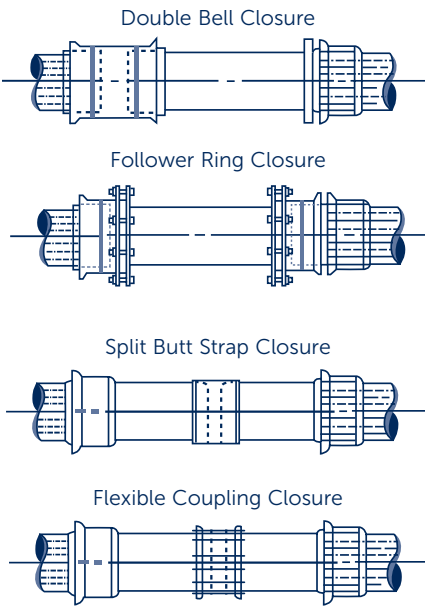

Valve Chambers

Valve chambers are the best example of the versatility of Concrete Pressure Pipe fittings. Wall pieces can be anchored in the concrete walls with a thrust flange, which also serves as a water stop. Drains and air vents can be achieved by a simple outlet. Flanges or any special end can be used to connect to valves or special couplings. Special outlets can be supplied for installation of equipment or connection to other lines. All of the features described above can generally be incorporated into two compact wall pieces and other fittings required for the valve chamber.

Custom Made Fittings

Special fittings are custom made. The size and length of required tees, elbows, reducers, and other fittings can be adjusted to fit complex layouts. If necessary, many features such as special ends, reducers, outlets, and wall flanges can be combined into the same fitting. By so doing, the number of joints is reduced, thus simplifying installation, minimizing space requirements, and lowering overall project costs.

Special fittings for field adjustments may be unforeseen while the project is on the drawing board. However, different types and sizes of fittings are available for most situations. Also in stock are closure assemblies for urgent replacement of existing pipe sections.

LEARN MORE

For assistance in developing the most effective pipe system layout, speak with your Concrete Pressure Pipe supplier, or contact the American Concrete Pressure Pipe Association at **714.801.0298** or **www.acppa.org**.

TECHNICAL ASSISTANCE

Each Concrete Pressure Pipe manufacturer has a catalogue depicting standard dimensions for common fittings and joint types. The dimensions assist the designer in determining the length of standard fittings or specials as available from the manufacturer.



ACPPA Headquarters
T 714.801.0298
email: support@acppa.org
www.acppa.org