

RESTRAINED JOINTS

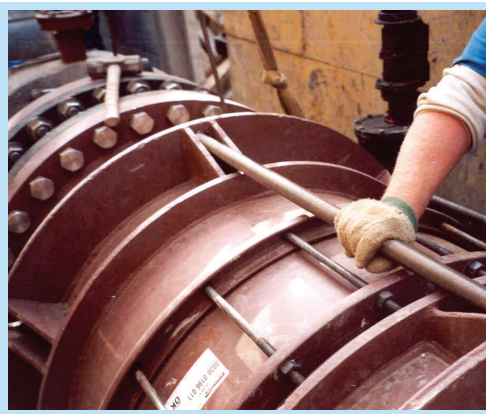

Installing restraining rods over flexible coupling.

Water and wastewater pipelines, under internal pressure, will experience unbalanced forces in the system as fluid flow is altered by change in direction. Such forces, if not properly restrained, could cause the pipeline to move and disengage at the joints. Unbalanced forces occur at elbows, wyes, tees, reducers, bulkheads, and closed valves. Since most water lines operate at flow velocities less than 10 feet per second, the hydrodynamic force is typically less than one percent of the unbalanced force from internal pressure. Consequently, hydrodynamic force is usually ignored when computing the unbalanced forces to be restrained.

Unbalanced forces resulting from deflections of unrestrained joints and of beveled pipe joints are restrained by the resistance due to the dead weight of the pipe, water weight in the pipe, and earth load, as well as the bearing pressure of the backfill. Supplemental restraint of deflected or beveled pipe joints is almost never required.

There are two methods generally used to resist the unbalanced hydrostatic forces in a pressurized pipeline at fittings and valves. One method is to restrain the joints; the other is to use a concrete thrust block behind the elbows, tees, wyes, and bulkheads, or cast concrete thrust collars on pipe adjacent to the fitting.

Concrete thrust blocks are the most common and usually the most economical method for restraining thrust. Thrust blocks depend upon the bearing capacity of the in situ soil material behind the block. In weak or unstable soils, or where future excavation around the pipeline can be anticipated, restrained joints may be the more appropriate solution. Future underground

construction could potentially disturb the soil behind the thrust block, allowing the block to move and possibly disengaging a pipe joints.

For such conditions, restrained joints provide a proven alternative thrust restraint system. The unbalanced force that develops at a fitting can be countered with sufficient external pipe wall-to-soil frictional and soil bearing resistance by tying the pipeline joints together for a sufficient distance from the fitting. The number of pipe joints to be restrained is determined by the magnitude of the frictional resistance of the pipe against the soil and the passive resistance of the soil to transverse movement of the pipe. The frictional

resistance is calculated by evaluating the weight of the soil acting on the top and bottom of the pipe, the pipe weight, and the water weight in the pipe, multiplied by a coefficient of the friction between the pipe and soil. Compacting the soil around the pipe can increase the effectiveness of the coefficient of friction.

In identical soils, the coefficient of friction on concrete pressure pipe with mortar coating (i.e. on AWWA C301 and C303 concrete pressure pipe types) will be greater than on pipe made with smooth exterior surfaces due to the roughness of the exterior surface of the mortar-coated concrete pressure pipe, but the differences may not be significant and are generally not calculated.

The unbalanced forces at bulkheads, tees and reducers can be calculated by multiplying the internal pressure P (psi) by the difference in pressurized cross sectional area A (in²) at the pipe joint from one side of the fitting to the other.

The solution for restrained length and cylinder thickness at a bend requires an iterative process to simultaneously solve several equations. Sample equations are shown in *AWWA M9 (3rd Edition; Chapter 9)*. ACPPA maintains and offers the Thrust Restraint Design Program (TRDP) software which is available as a free download to solve the simultaneous equations. The M9 Manual also contains five soil types with suggested design values for k , μ , soil density, and ϕ (angle of internal friction) that are used by the TRDP software. The following is a brief overview of the concepts presented in the M9 Manual.



Snap Ring® joint provided on Concrete Pressure Pipe.

The resultant unbalanced force at a bend requires evaluation of the effect of the deflection angle, Δ , and is given by:

$$T = 2 P A \sin (\Delta/2) = 2 F_o \sin (\Delta/2) + 2 V_o \cos(\Delta/2) + 2 k \delta l_b \cos(\Delta/2)$$

where T , the unbalanced force, is expressed in pounds when P is in psi and A is in square inches. The pipe connected to an elbow will experience an axial thrust force, a shear force, and a bending moment.

F_o = axial thrust force in the pipe, lbs.

V_o = shear force in the pipe, lbs.

k = soil stiffness against outward movement of the pipe or fitting, lbs/inch/inch

δ = outward movement of fitting, inches

l_b = centerline distance, inches, from the point of intersection of the elbow to the end of the mortar or concrete lining at the bell end of the first restrained joint, inches

The term; $2k\delta l_b \cos (\Delta/2)$ represents the passive soil resistance component of the resisting force. The bending moment is calculated from the shear force, V_o , using a beam on elastic foundation analysis.

The frictional resistance per linear foot of pipe against the soil, f_μ is equal to:

$$f_\mu = \mu [(1 + \beta)W_e + W_p + W_f]$$

where:

β = shallow cover factor (as defined in *AWWA M9, 3rd Edition; Chapter 9*), ≤ 1

μ = coefficient of friction

W_e = weight of earth over pipe, lbs/ft.

W_f = weight of fluid inside pipe, lbs/ft.

W_p = weight of pipe, lbs/ft.

As a practical matter, as long as the depth of cover is at least equal to the outside diameter of the pipe, $\beta = 1$.

The length of pipe, L (feet), to be tied to each leg of the bend is calculated as:

$$L = \frac{F_o}{\mu [(1 + \beta)W_e + W_p + W_f]}$$

where: F_o = axial thrust force in the pipe, lbs.

The length of pipe to be tied to a bulkhead is:

$$L = \frac{PA}{\mu [(1 + \beta)W_e + W_p + W_f]}$$

Unbalanced forces at in-line fittings such as valves, reducers, or internal test plugs can be restrained by the friction on the downstream pipe transmitted by compression through the grouted joints. If all the joints are properly grouted, restraining of joints is usually not required. Unbalanced forces at downward turning, vertical elbows is resisted by the dead weight of the pipe, water weight in the pipe and earth load on the pipe. If that resistance is not adequate to counteract the force, then the elbow must be restrained to a sufficient length of adjoining pipe to resist the uplifting force. Unbalanced forces at upward turning vertical elbows can be restrained in the same manner as horizontal elbows.

TYPES OF RESTRAINED JOINTS

There are two general types of restrained joints: (1) field-welded joints and (2) mechanically-restrained joints (see Figures 9-25 and 9-25 in *AWWA Manual M9*, respectively, reprinted herein). A field-welded joint is rigid. A mechanically-restrained joint is "mostly rigid" but still capable of small movements after installation. The allowance of slight movement allows mechanically-restrained joints to adjust to minor trench settlements and results in a lower stress from bending moment when compared to the stresses from bending moments acting across a fully rigid joint.

Field Welded Joints

There are two types of field-welded joints. The exterior field-welded joint involves the use of a mild steel filler rod between the bell ring flare and the shank of the spigot ring. The leading edge of the bell is welded to the steel rod and the shank of the spigot is welded to the steel rod. If a full circumferential weld is not required, the required length of weld may be equally divided into shorter weld segments. Such segments must be equally-spaced around the pipe circumference so the centroid of the welding is at the centerline of the pipe.

The interior field-welded joint is made by welding the leading edge of the spigot to the bell. If the force to be restrained is sufficiently high, the gasket groove must be trimmed to allow welding to the thickest part of the spigot. Otherwise, use of gaskets in untrimmed internally welded joints may be helpful to keep exterior joint grout, groundwater, or water used for backfill consolidation out of the pipe prior to and during joint welding. If a gasket is used in the joint to be welded on the inside, the joint should be seal-welded by the skip-weld method to prevent the welder from being exposed to fumes from a burning gasket rubber. Since the proximity of a rubber gasket (if used) to the internal weld will likely cause the gasket to burn, the weld must be made fully circumferential and watertight.

Mechanically Restrained Joints

Pipe and fitting joints can also be tied together with mechanical restraints. The two types of mechanically restrained joints most commonly used are:

- Clamp type, which utilizes two semi-circular halves bolted together in the field; and
- Snap Ring® type, which has a Snap Ring® insert recessed into a groove in the bell and tightened down

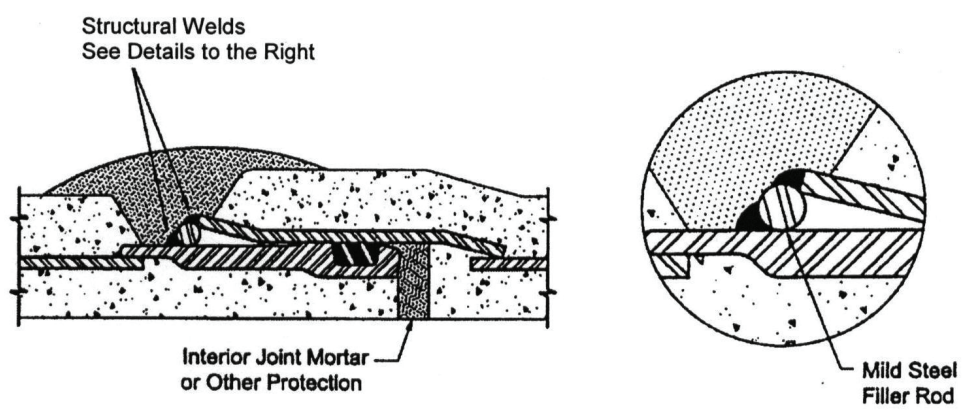

External Welded Restrained Joint

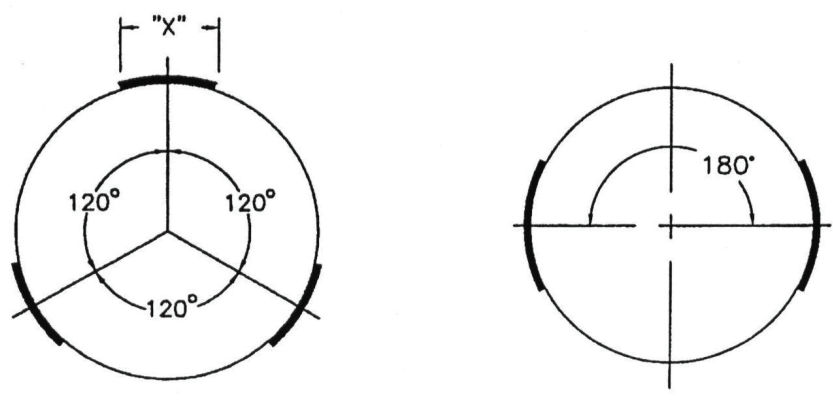

With Joint End Views of Skip-Weld Placement, To Be Used Only With Gasket Installed

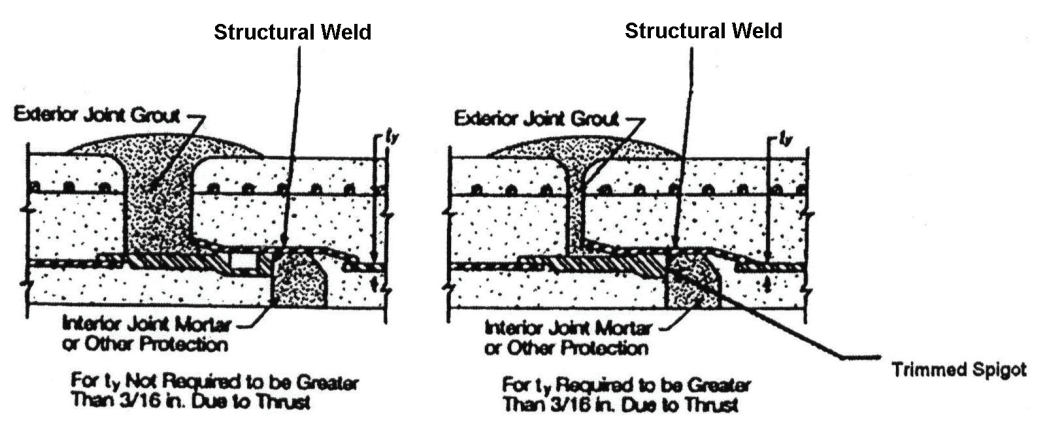

Internal Welded Restrained Joint

Figure 9.24 Typical welded Concrete Pressure Pipe joints. Reprinted from AWWA Manual M9, 3rd edition by permission. Copyright © 2008 the American Water Works Association.

Harness clamp comes in two semicircular halves bolted together in the field.

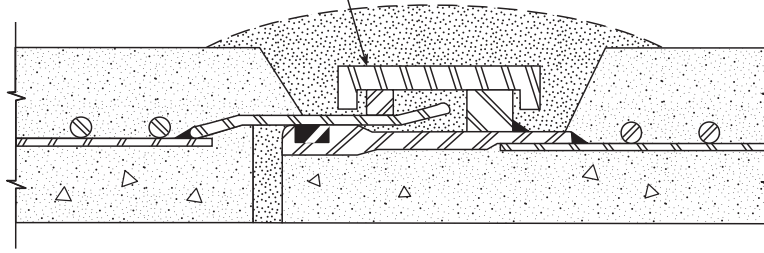

A. Clamp-type harness

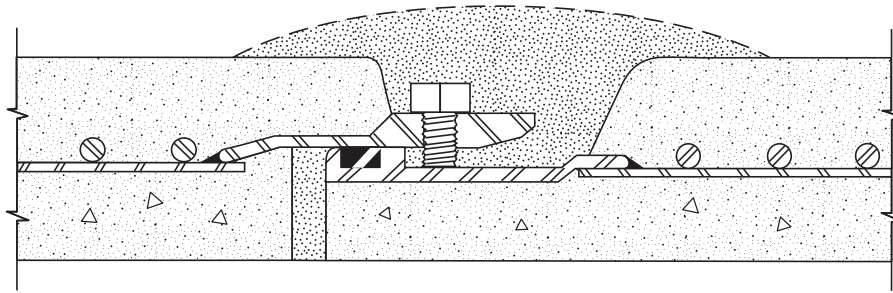

B. Bell-bolt type harness

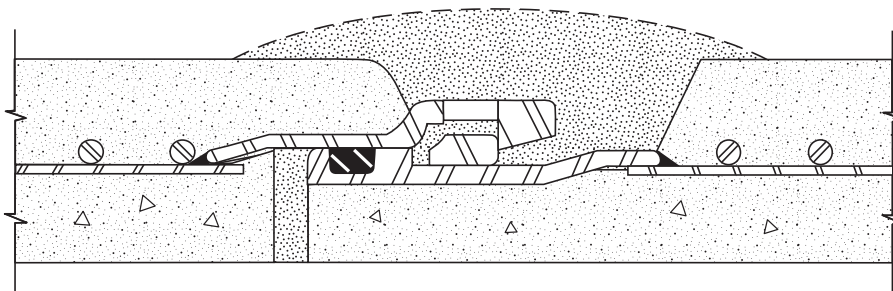

C. Snap-ring type harness

NOTE: For clarity, not all welds are shown.

Figure 9.25 Typical harnessed joints for Concrete Pressure Pipe. Note: Bell-bolt joint detail is provided for historical reference only, and is not available for new construction. Reprinted from AWWA Manual M9, 3rd edition by permission. Copyright © 2008 the American Water Works Association.



Hanessed clamp delivered on Prestressed Concrete Pipe.

behind the spigot groove, by the installing contractor, after the joint is home.

Transmission of Longitudinal Forces

The unbalanced force at the fitting is transmitted to the steel cylinders in the connected pipe through the restrained joint rings. In concrete cylinder pipe (AWWA C300, AWWA C301, and AWWA C303 types), the steel cylinder is used to transmit the longitudinal force and bending moment from the joint rings at one end of the pipe to the joint rings at the other end of the pipe. Therefore, the steel cylinder must be of sufficient thickness to withstand the force and bending moment and remain within its allowable tensile stress. The maximum cylinder thickness required will be in the pipe length adjacent to the fitting. Cylinder thickness is reduced, along the restrained length, L , as the force and bending moment is dissipated due to soil friction and passive soil resistance. The steel cylinder thickness can be reduced from the maximum down to the standard thickness in a linear manner along the restrained length. In non-cylinder concrete pressure pipe (AWWA C302 type), the forces are transmitted through the longitudinal steel reinforcement.

OTHER APPLICATIONS FOR RESTRAINED JOINTS

There are other uses for restrained joints. In laying pipe down a steep slope, the joints may be restrained in order to prevent the pipe from sliding downhill and opening the joints. When laying pipe across a river or in unstable soil, it may be appropriate to restrain the joints to prevent them from opening due to excessive settlement.

Subaqueous installation of intake and outfall lines may utilize longer lengths of pipe to save on installation costs. In such cases, standard pipe lengths can be welded together either at the plant or in the field to form longer lengths. This reduces the number of joints that the contractor needs to make under water. Another consideration for using longer length pipe would be installing pipe on pile supports. Welding standard lengths together with a full circumferential weld will result in a pipe able to span longer lengths, thus reducing construction costs by eliminating pile supports.

SUMMARY

Concrete Pressure Pipe provides the pipeline and system designer with considerable flexibility for producing the optimum system capabilities. Your Concrete Pressure Pipe manufacturer can provide customized engineering plans to aid in system design and construction.

LEARN MORE

For more information on designing and installing restrained joints, speak with your Concrete Pressure Pipe supplier, or contact the American Concrete Pressure Pipe Association at **714.801.0298** or www.acppa.org.



ACPPA Headquarters
T 714.801.0298
email: support@acppa.org
www.acppa.org