

CONCRETE PRESSURE PIPE

REPAIR GUIDE



TABLE OF CONTENTS

CONCRETE PRESSURE PIPE – REPAIR GUIDE



Introduction.....	1
Emergency Phone Numbers	1
Emergency Repair Questionnaire	2
Making a Durable Repair.....	4
Types of Concrete Pressure Pipes.....	5
AWWA C303, also known as “Bar-Wrap”, “Concrete Cylinder”, or “B-303” pipe	
AWWA C301, Lined Cylinder (“L-301”) and Embedded Cylinder (“E-301”) prestressed concrete pipe	
AWWA C300, AWWA C302, and Non-Cylinder Prestressed Concrete Pipe	
Concrete Pressure Pipe Fittings and Mortar-Coated Steel Pipe.....	10
Repair Procedures	
Quick Reference - (Repair Selection Guide).....	11
Mortar or Concrete.....	14
Heat & Reshape or Weld On New Joint Ring.....	15
Spigot Field Adjustment.....	16
Exterior Joint Weld	18
Interior Joint Weld	19

These more-demanding repair procedures require specific materials and/or expertise and so are not described on the ACPPA website. Contact your ACPPA member concrete pressure pipe supplier for full details and support.

- Welded Repair
- Weld-On Repair Saddle
- Gasket Repair Saddle for Noncylinder Pipe
- Dry Tap
- Damaged Pipe Removal for Closure Placement
- C-303 Split Joint Pipe Insertion
- C-303 Cut Pipe Closure
- Reinforcing Clamp
- Internal Cylinder Repair

NOTE: The information presented herein was originally prepared by U.S./Forterra Pressure Pipe. ACPPA gratefully acknowledges their contribution.

INTRODUCTION

Pressure pipe, when properly designed, manufactured and installed, will provide safe, reliable and continuous service under normal and transient conditions. Unfortunately, due to accidents or other unforeseen circumstances, it is sometimes necessary to repair or replace a pipe in the line.

Though durable, this pipe is not designed to withstand impact from a backhoe, jackhammer or an auger. This Repair Guide will provide a course of action to follow should such an event occur.

ACPPA member companies stock repair and replacement clamps, saddles, pipe sections, closures and other materials at many of their manufacturing facilities. The fittings departments can quickly fabricate non-stock repair materials from steel plate inventory.

This Guide describes the most common repair procedures; however, not all repairs are covered. Concrete Pressure Pipe manufacturer's field representatives have extensive knowledge in repair procedures and can usually offer a practical solution to most situations.

For the best feedback in an emergency, make a record of the types and sizes of pipe in the system. It may also be helpful to provide a sketch showing the location, size and type of pressure pipe. Use the Emergency Repair Questionnaire on page three.

EMERGENCY PHONE NUMBERS

DECAST, Ltd.: 888-835-7940, anytime

Forterra Pressure Pipe, Canada: 888-497-7371

Thompson Pipe Group - Pressure: 972-262-3600 or 800-543-5147 during normal business hours Central time, or 800-445-1534 evenings, weekends, or holidays

ASSOCIATE MEMBER:

Rangeline Pipeline Services LLC: 682-250-2153 during normal business hours, Central time, or 888-722-7457 after hours/emergency

NOTE

The information in this Repair Guide is descriptive and provided for the benefit of, and consideration by, pipeline owners. This Guide is made available with the understanding that the authors and American Concrete Pressure Pipe Association (ACPPA) are not herewith or herein rendering engineering or any other professional services. This Guide is intended for the use of licensed engineers. As a result of changes in manufacturing processes, technology, and pipeline specifications, information contained in this publication may become outdated. It is the responsibility of the engineer using this material to use independent professional judgment and to update the information to ensure accuracy when dealing with individual repairs. All operations described in this Guide should be performed only by qualified individuals in accordance with the Occupational Safety and Health Act (OSHA) and other regulations, provincial, state and local codes, and recognized safe practices, particularly those related to personal protective equipment and trench and confined space entry. ACPPA disclaims all warranties associated with this Guide or its content. In no event will the authors or ACPPA be liable for any direct, indirect, or consequential damages resulting from the use of this material.

EMERGENCY REPAIR QUESTIONNAIRE

If an emergency repair is needed, please try to answer these questions before calling a Concrete Pressure Pipe manufacturer for assistance.

1. DO YOU KNOW:

The pipe manufacturer? _____

Job number? _____

Installation date? _____

2. WHAT IS THE SIZE AND TYPE OF THE DAMAGED PIPE?

Inside diameter _____

- Bar-Wrapped Cylinder Concrete Pipe (AWWA C303, aka "CCP", "P-303", "Pretensioned Concrete Cylinder Pipe", "Concrete Cylinder" or "B-303" pipe)
- Prestressed Concrete Lined Cylinder Pipe (AWWA C301, aka "L-301" or "SP-5")
- Prestressed Concrete Embedded Cylinder Pipe (AWWA C301, aka "E-301" or "SP-12")
- Reinforced Concrete Cylinder Pipe (AWWA C300, aka "V-300", "SP-3")
- Reinforced Concrete Noncylinder Pipe (AWWA C302, aka "SP-1", "SP-25", "SP-32" or "ASTM C361")
- Prestressed Concrete Noncylinder Pipe ("NC-301", "SP-23", "SP-28", or "SP-31")
- Steel Pipe (S-200) (Mortar-coated steel pipe may appear to be concrete pipe.)
- Reinforced Concrete Pipe ("ASTM C76", "ASTM C655", or "AASHTO M170" culvert or storm drain pipe, which can be repaired in the same manner as AWWA C302)

3. If the type of damaged pipe is unknown, what is the outside measured circumference? _____

4. Does the damaged pipe have an outlet?

Outlet size _____

Outlet joint type:

- CPP bell or spigot joint
- Flange joint
- MJ Bell
- Plain end
- Other _____

5. Is the damaged pipe a fitting?

- Tee/Wye
- Bend (angle of deflection)
- Reducer
- Adapter (type of joints)
- Other _____

6. Is the damaged pipe a special piece?

- Bevel
- Restrained joint
- Pipe is double coated, painted, bonded, etc.

7. What is the laying length of the damaged pipe? _____

8. What is the operating pressure of the line?

PSI _____

Feet of Head _____

9. Can the pipe be depressurized? _____ Drained? _____

10. What is the line's purpose? _____

11. Type of coating (if steel pipe) _____

12. What are the dimensions of the damaged area? _____

13. Do you have clear directions to the site of the damage or to a delivery point? _____

14. Do you have the name and phone number of the key person to contact? _____

If yes, please provide: _____

15. Do you need experienced personnel to assist in the repair? _____

MAKING A DURABLE REPAIR

Completed repairs on concrete and steel pressure pipe should provide both the strength to contain the pipeline pressure and protection from corrosion.

Pressure containment strength is generally established by assuring adequate gasket compression, by welding, by installing additional circumferential reinforcement on existing pipe or by pipe replacement.

Corrosion protection of the repair is generally provided by coating all exposed steel with a 1" (25 mm) minimum thickness of Portland cement mortar.

If the pipeline being repaired is bonded for monitoring or cathodic protection, the repair steel should also be electrically connected to the pipeline steel.

The proper procedure to repair leaks in damaged pressure pipe depends on the pipe type. The type of pipe determines whether the pipe has a cylinder, the location of the cylinder in the pipe wall and whether the pipe is prestressed.

Cylinder thickness on some types of concrete pressure pipe can be as thin as 18 gauge, (0.05"), and some concrete pressure pipe cylinders were made with higher-strength cold-rolled steel. Only welders with experience on concrete pressure pipe should attempt repairs on pipe with thin cylinders or cylinders of high-strength steel.

TYPES OF CONCRETE PRESSURE PIPES

AWWA C303

Prior to 1970, this pipe was known as American concrete cylinder pipe or P-381. From 1970 to 1995, it was marketed as Concrete Cylinder Pipe or Pretensioned Concrete Cylinder Pipe (P-303). Since 1995, it has been marketed as Bar-Wrapped Pipe or "BWP", Concrete Cylinder Pipe, or B-303. This pipe is manufactured in diameters ranging from 10" (250 mm) to 72" (1830mm). The bell, spigot, cylinder and spiral reinforcing rod on this pipe are all made of mild steel and can be welded. However, the cylinder for C303 and other types of concrete pressure pipe can be as thin as 16 gauge (0.0598"/1.5 mm), so only welders experienced in making watertight welds on thin steel should attempt welding repairs on concrete pipe cylinders.

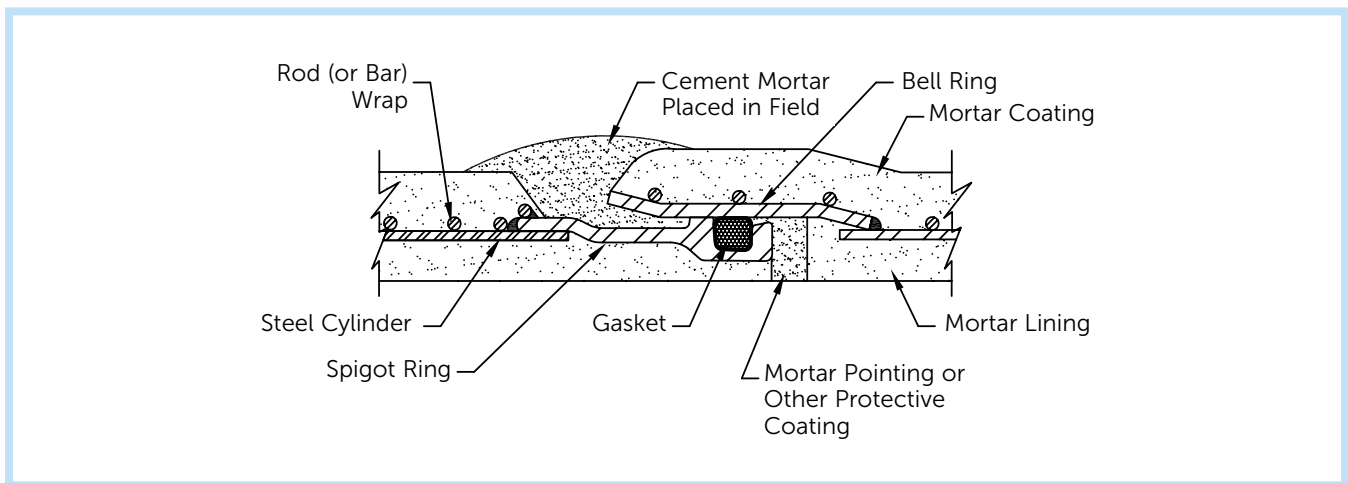

NOTE

The bell, spigot, cylinder and spiral reinforcing rod on C303 pipe are all made of mild steel and can be welded.

CAUTION

If the cylinder is 14 gauge (0.0747"/1.9 mm) or thinner, only a welder with experience on concrete pressure pipe should attempt the repair.

TYPES OF CONCRETE PRESSURE PIPES (Cont.)

AWWA C301

Prestressed Concrete Lined Cylinder Pipe (L-301, also marketed as SP-5) and Prestressed Concrete Embedded Cylinder Pipe (E-301, also marketed as SP-12) are commonly manufactured in the United States and Canada. Lined cylinder prestressed pipe has been manufactured in 16" (400 mm) through 60" (1500 mm) diameters and embedded cylinder prestressed pipe has been manufactured in 24" (600 mm) through 252" (6400mm) diameters. The bell, spigot and cylinder of these pipe are made of mild steel and the cylinder is usually 16 gauge (0.0598"/1.5 mm) material. The spiral prestressing wire is very high strength steel and cannot be welded. For this reason, repair procedures for these types of pipe usually use circumferential clamps or similar materials which do not require structural support from the prestressing wire.

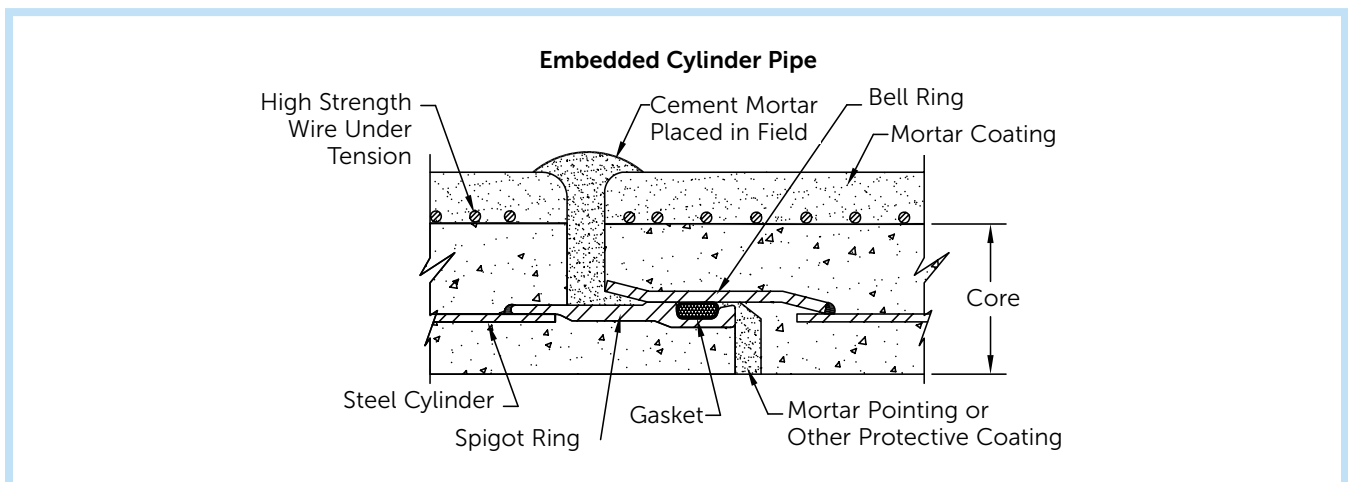
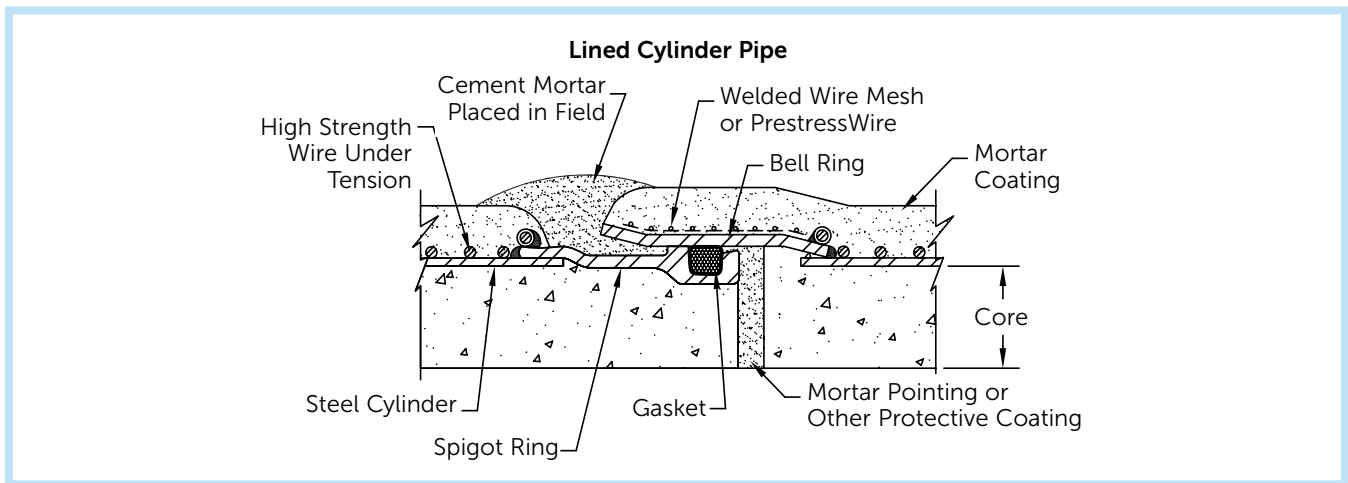

NOTE

The bell, spigot and cylinder of both types of C301 pipe are made of mild steel and the cylinder is usually 16 gauge (0.0598"/1.5 mm) material.

Repair procedures for C301 pipe use circumferential mild steel clamps or similar materials which do not require structural support from the prestressing wire.

AWWA C300, AWWA C302, AND NON-CYLINDER PRESTRESSED PIPE

There are several other types of concrete pressure pipe which are less commonly or no longer manufactured today but for which there are many miles installed and generally operating with very few problems. These include reinforced concrete cylinder pipe (AWWA C300, sometimes marketed as V-300, SP-3, or Lock Joint Cylinder pipe), reinforced non-cylinder concrete pipe (AWWA C302, sometimes marketed as SP-1, SP-25, or SP-32, depending on the type of joints, or as "C-302" when manufactured by spinning or "V-302" when manufactured by vertical casting the concrete), and prestressed noncylinder pipe (sometimes marketed as "NC-301", SP-23, SP-28, or SP-31).

AWWA C300 reinforced concrete cylinder pipe was marketed in diameters from 24" through 120". The pipe bell, spigot, cylinder and reinforcement are made of mild steel. The pipe cylinder is embedded several inches under the outer pipe wall surface.

Non-cylinder C302 and prestressed noncylinder pipe depend on the pipe wall concrete to contain the pipeline pressure. In these pipes, there is no steel cylinder against which a seal may be achieved so in some cases the best repair method is to remove and replace the pipe, often with another type of concrete pressure pipe that has a cylinder. Such a repair requires the existing adjacent pipe to have good joints to which the replacement pipe can be engaged or welded. C302 pipe may have any combination of steel or concrete bells and spigots. Noncylinder prestressed pipe has been made with a variety of steel or concrete belts and spigots, and some was made with double concrete spigots with a fiberglass double-width bell.

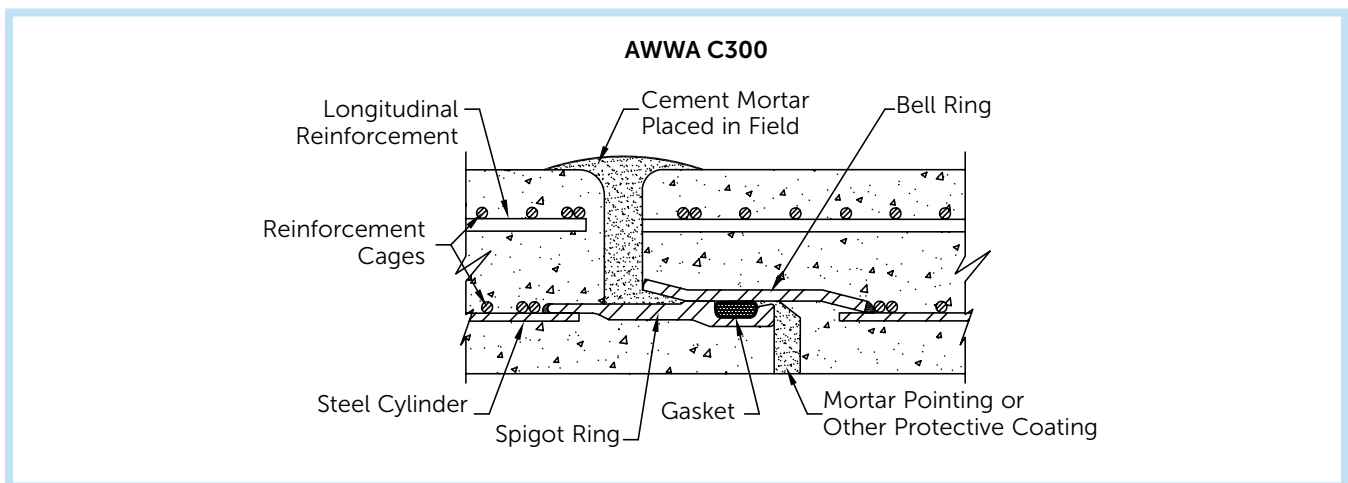

NOTE

The bell, spigot, cylinder and reinforcing rod on C300 pipe are all made of mild steel and can be welded.

CAUTION

If the cylinder is 14 gauge (0.0747") or thinner, only a welder with experience on concrete pressure pipe should attempt the repair.

TYPES OF CONCRETE PRESSURE PIPES (Cont.)

AWWA C300, AWWA C302, AND NON-CYLINDER PRESTRESSED PIPE (CONT.)

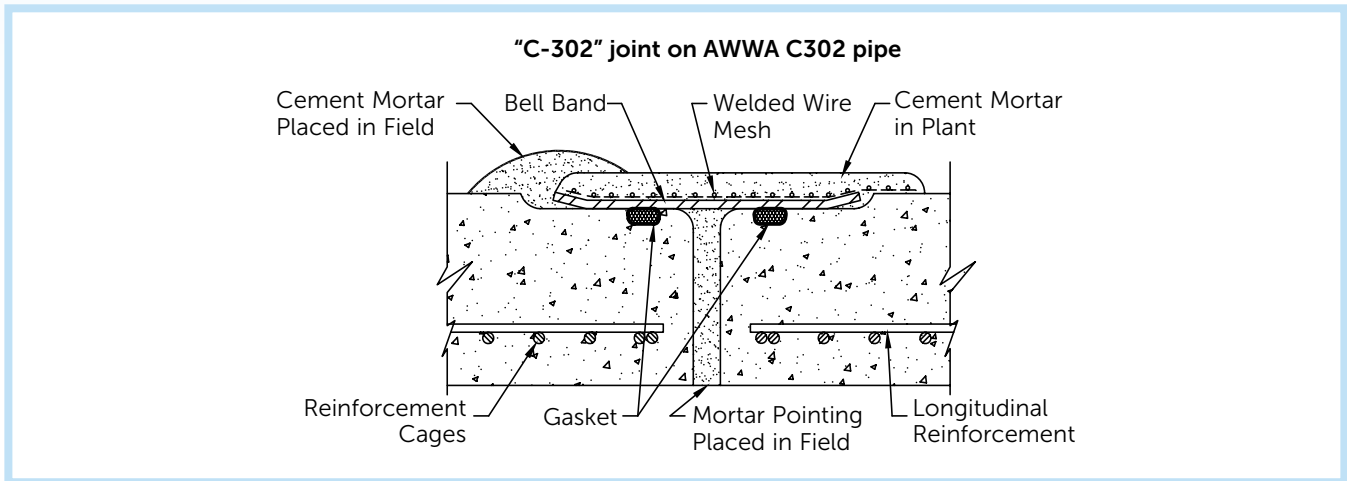

NOTE

C-302 and V-302 are non-cylinder pipe with smooth exterior surfaces. Holes in these pipe walls can often be sealed by compressing a gasket or rubber pad against the outside of the pipe.

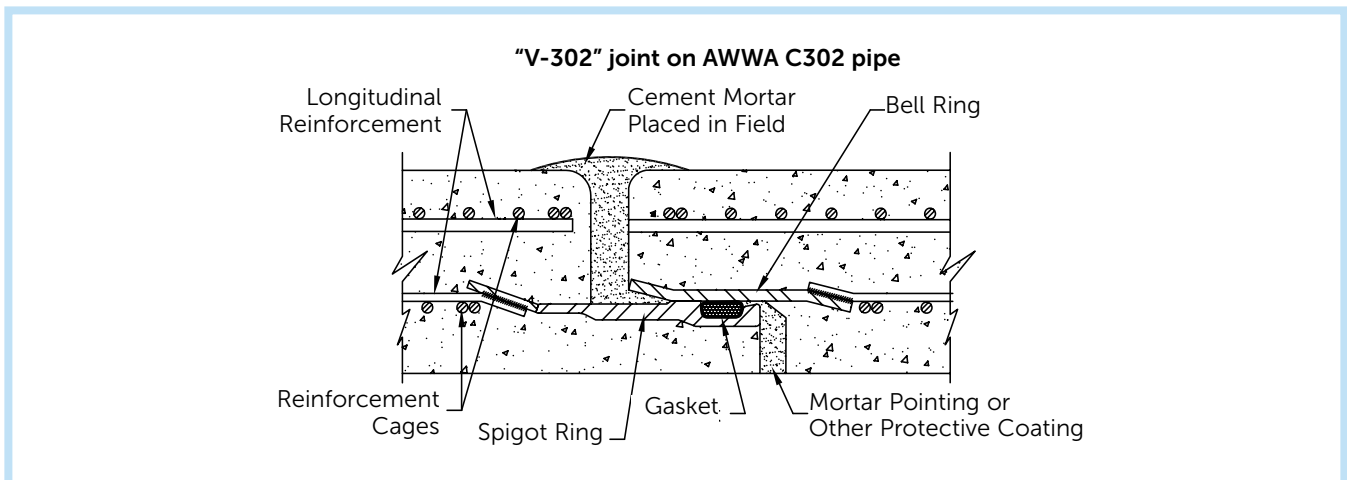

NOTE

Some V-302 and NC-301 pipe have steel bells and spigots which can be welded to seal joint leaks. An alternate style of "V-302" joint has concrete bells with a larger outside diameter than the barrel of the pipe, and concrete spigots.

AWWA C300, AWWA C302, AND NON-CYLINDER PRESTRESSED PIPE (CONT.)

C302 pipe with centrifugally-placed concrete was marketed in diameters from 12" through 84". C302 pipe with vertically-cast concrete pipe was marketed in sizes from 36" through 120". Noncylinder prestressed was made in 72", 78", 96", 108", 120", 216", and 252" diameters.

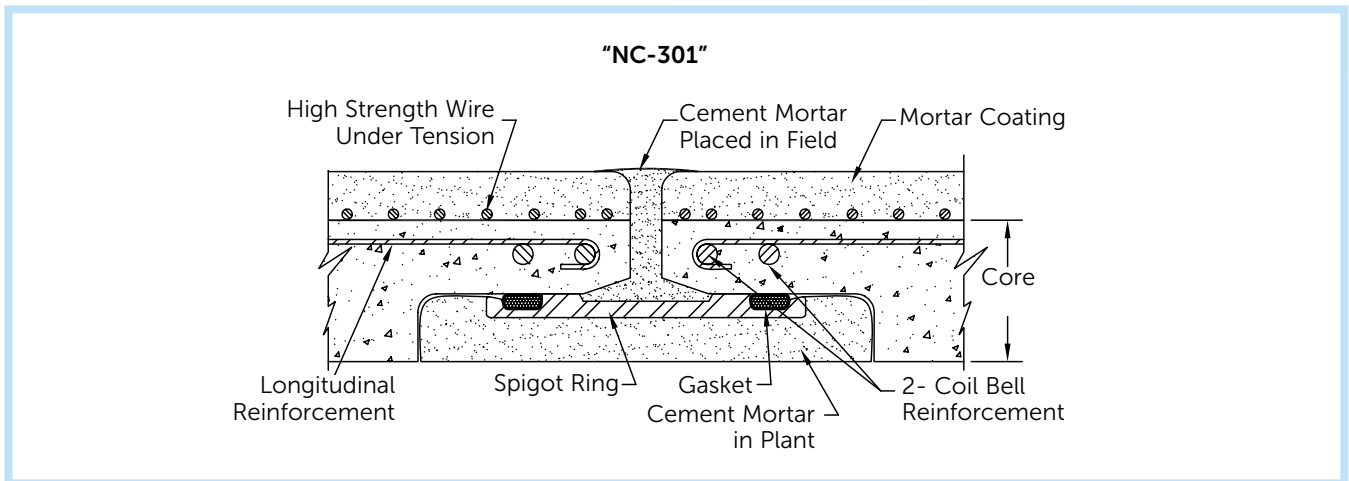
**NOTE**

Other joint configurations have been used for noncylinder prestressed pipe.

CONCRETE PRESSURE PIPE FITTINGS AND MORTAR-COATED STEEL PIPE

Bends, tees, and other concrete pressure pipe fittings are made of welded steel that is lined and coated with wire-reinforced mortar. Fittings can usually be repaired following the applicable steps for repairing AWWA C303 pipe.

When excavated, mortar-coated steel pipe may appear to be concrete pressure pipe. In some areas, both mortar coated steel pipe and bar-wrapped concrete pipe are collectively (and incorrectly) called "concrete cylinder pipe" and/or "steel cylinder pipe." The pipe can sometimes be identified by a difference in outside diameter between mortar-coated steel pipe and mortar-coated concrete pressure pipe. Mortar-coated steel pipe has wire reinforcement in the middle third of the mortar coating thickness instead of reinforcing bar or prestressing wire being wrapped directly on the cylinder. In diameters smaller than 30", some mortar-coated steel pipe has been made with cylinders that are 14 gauge (0.0747") and thinner. Such cylinders require very experienced welders. Larger diameter steel pipe has thicker cylinders that are less likely to be accidentally perforated during welding.

As with concrete pressure pipe fittings, mortar-coated steel pipe can usually be repaired following the applicable steps for repairing AWWA C303 pipe.

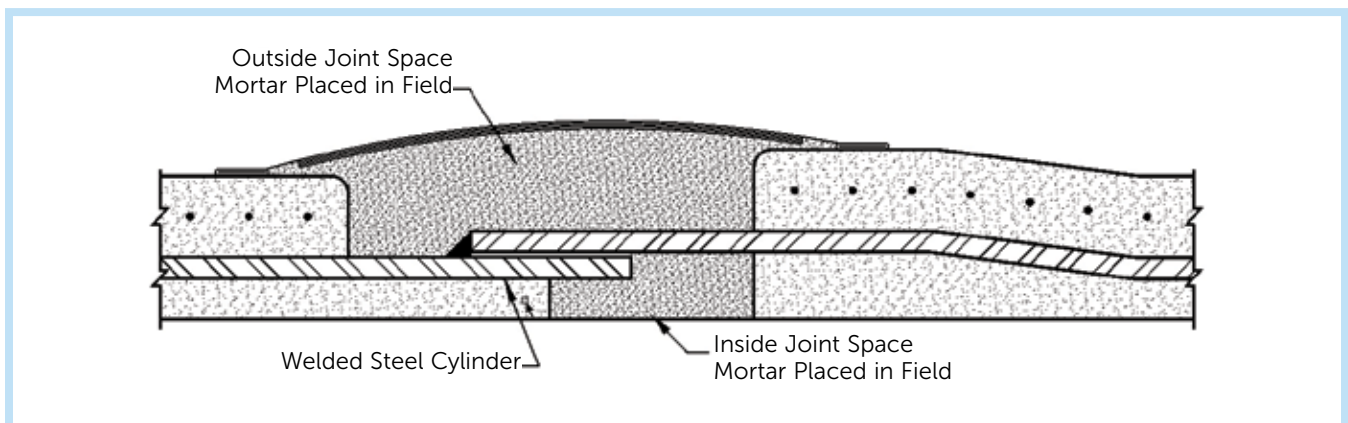
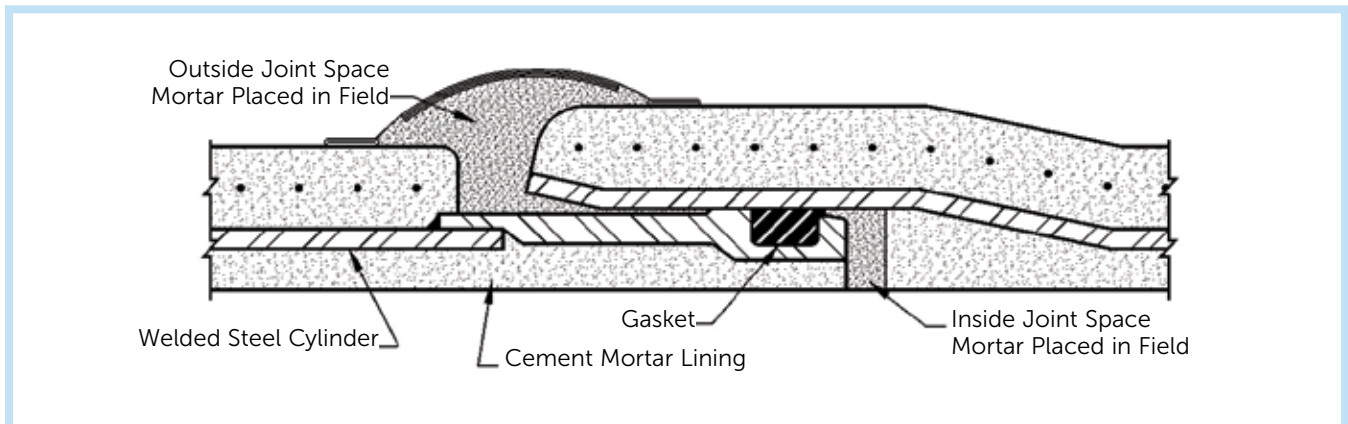

REPAIR PROCEDURES

QUICK REFERENCE

Typical repair procedures for various types of pipe and conditions are listed here. Some repairs can be made with the pipeline pressurized, provided there is no leak with sufficient water volume or pressure to endanger repair personnel.

Other repairs can be made with the pipeline full but depressurized in order to reduce leakage to a level which will not interfere with the installation of the repair. Where pipe sections must be replaced, the line must be drained.

Any steel used in repairs on electrically bonded pipelines must be made electrically continuous with the pipeline steel and all repair and pipe steel must be properly protected with Portland cement mortar.

Cylinder thickness on some types of concrete pressure pipe can be as thin as 18 gauge, (0.05"), and some concrete pressure pipe cylinders were made with higher-strength cold-rolled steel. Only welders with experience on concrete pressure pipe should attempt repairs on pipe with thin cylinders or cylinders of high-strength steel.

PROBLEM	REPAIR	PAGE
REPAIR OF MORTAR OR CONCRETE		14
AWWA C303 AND MORTAR-COATED STEEL PIPE		
Joint repairs during new pipe installation		
• Bent joint ring	Heat & reshape or weld on new joint ring	15
• Larger (>30"/760 mm) pipe with groundwater seeping or gap between bell and spigot	Spigot field adjustment	16
• Insufficient joint overlap		
All diameters	Exterior joint weld	18
Larger (>30"/760 mm) diameters	Interior joint weld	19
Joint repairs on existing pipe		
• Pipe under low or no pressure		
All diameters – slight or no seeping	Exterior joint weld	18
Larger (>30"/760 mm) diameters (requires draining & access to interior)	Interior joint weld	19
• Pipe under operating pressure	Weld-on repair saddle	*
Pipe barrel repairs		
• Pipe not under pressure		
Steel damaged but lining intact	Welded repair	*
	or Internal Cylinder Repair	*
Steel and lining damaged	Dry tap	*
Hole drilled in pipe barrel	Dry tap	*
• Pipe under pressure	Weld-on repair saddle	*
Pipe replacement		
	Split Joint Pipe Insertion	*
	Cut pipe closure	*

* Contact your ACPA member concrete pressure pipe supplier for full details and support.

REPAIR PROCEDURES (Cont.)

QUICK REFERENCE (CONT.)

PROBLEM	REPAIR	PAGE
LINED-CYLINDER AWWA C301		
Joint repairs during new pipe installation		
• Bent joint ring	Heat & reshape or weld on new joint ring	15
• Larger (>30"/760 mm) pipe with groundwater seeping or gap between bell and spigot	Spigot field adjustment	16
• Insufficient joint overlap		
All diameters	Exterior joint weld	18
Larger (>30"/760 mm) diameters	Interior joint weld	19
Joint repairs on existing pipe		
• Pipe under low or no pressure		
All diameters – slight or no seeping	Exterior joint weld	18
Larger (>30"/760 mm) diameters (requires draining and access to interior)	Interior joint weld	19
• Pipe under pressure	Weld-on repair saddle	*
Pipe barrel repairs		
• Pipe not under pressure; wire damaged but cylinder intact	Reinforcing clamp	*
• Hole drilled in pipe barrel	Dry tap	*
• Pipe under pressure (temporary repair)	Weld-on repair saddle	*
EMBEDDED-CYLINDER AWWA C301		
Joint repairs during new pipe installation		
• Bent joint ring	Heat & reshape or weld on new joint ring	15
• Larger (>30"/760 mm) pipe with groundwater seeping or gap between bell and spigot	Spigot field adjustment	16
• Insufficient joint overlap	Interior joint weld	19
Joint repairs on existing pipe		
Pipe barrel repairs		
• Pipe not under pressure; wire damaged but cylinder intact	Reinforcing clamp	*
• Hole drilled in pipe barrel	Dry tap	*

* Contact your ACPA member concrete pressure pipe supplier for full details and support.

PROBLEM	REPAIR	PAGE
AWWA C300		
Joint repairs on existing pipe		
<ul style="list-style-type: none"> • Pipe not under pressure 	Exterior joint weld or interior joint weld	18 19
<ul style="list-style-type: none"> • Larger (>30"/760 mm) pipe with groundwater seeping or gap between bell and spigot 	Spigot field adjustment	16
<ul style="list-style-type: none"> • Pipe under pressure 	Weld-on repair saddle	*
Pipe barrel repairs		
<ul style="list-style-type: none"> • Pipe not under pressure; steel damaged but lining intact 	Welded repair	*
<ul style="list-style-type: none"> • Hole drilled in pipe barrel 	Dry tap	*
<ul style="list-style-type: none"> • Cylinder damaged and pipe exterior inaccessible 	Internal Cylinder Repair	*
<ul style="list-style-type: none"> • Pipe under pressure 	Weld-on repair saddle	*
AWWA C302		
Joint repairs on existing pipe		
<ul style="list-style-type: none"> • C302 pipe not under pressure 	Interior joint weld	19
	Pipe replacement	*
<ul style="list-style-type: none"> • Pipe under pressure or not 	Gasket repair saddle	*
Pipe barrel repairs		
<ul style="list-style-type: none"> • Pipe under pressure 	Gasket repair saddle	*
<ul style="list-style-type: none"> • Hole drilled in pipe barrel 	Dry tap	*
	Reinforcing clamp	*
	Pipe replacement	*
NONCYLINDER PRESTRESSED PIPE		
Joint repairs on existing pipe with steel joint rings		
<ul style="list-style-type: none"> • Pipe not under pressure 	Interior joint weld	19
<ul style="list-style-type: none"> • Pipe barrel repairs 	Gasket repair saddle	*
	Pipe replacement	*
<ul style="list-style-type: none"> • Hole drilled in pipe barrel 	Dry tap	*
	Reinforcing Clamp	*
	Pipe replacement	*

* Contact your ACPPA member concrete pressure pipe supplier for full details and support.

NOTE

Many of the repair and tapping procedures for steel pressure pipe are the same as for concrete pressure pipe, with a few subtle differences. For more information, please contact ACPPA or your local Concrete Pressure Pipe manufacturer.

REPAIR PROCEDURES (Cont.)

MORTAR OR CONCRETE

Repair of Unlaid Pipe or Interior Repairs on Installed Pipe

1. Chip back to sound lining or coating. The borders of the sound material around the repair area should be slightly undercut to key the repair mortar in place. Care must be taken during chipping to avoid nicking any steel, especially any cylinder or prestressing wires.
2. Clean and wet the surface of the repair area. Apply a thick cement slurry to the area to be patched.
3. Ram and compact a stiff mortar into the repair area. The mortar shall be worked under the borders of the surrounding mortar or concrete and under or around any exposed reinforcement or prestressing wire. Wire mesh may be useful for supporting the mortar over large repair areas.

The surface of the repair mortar shall be shaped to the pipe contour in a manner assuring there is at least $\frac{3}{4}$ " (19 mm) coverage over any pipe steel, (except reinforcing wire or mesh designed to be placed in the middle $\frac{1}{3}$ of the mortar).

4. The repair mortar can be one part cement to three parts sand mixed with as little water as possible so the mortar will be very stiff but workable. Repairs made with such mortar should be protected while being cured for 24 hours using intermittent water spray, wet covering, plastic sheet or a curing compound. Any curing compound should be NSF approved for contact with potable water.

Alternatively, the repair mortar can be a high pH, low chloride, quick set mortar so the repair will harden quickly and require no special curing procedures.

Exterior Repairs on Installed Pipe

Exterior mortar or concrete repairs on installed pipe can be made as outlined above. Alternatively, after the exterior damaged mortar or concrete has been removed and the area of damage cleaned, and inspected to assure cylinder and wire integrity has not been compromised, the pipe exterior can be encased with mortar or concrete. This can be accomplished either by placing a joint wrapper to straddle the repair area and filling the wrapper with mortar, or by backfilling the trench pipe zone in the repair area with concrete or mortar.

All mortar repairs should be protected from freezing until they have cured.

HEAT & RESHAPE OR WELD ON NEW JOINT RING

Repair Procedure

1. Joint rings which are misshaped due to being bumped during or after delivery can sometimes be heated and hammered back to essentially their original configuration. Such a repair must only be made: (a) with the approval of the owner's inspector or representative; and (b) under the supervision of the concrete pressure pipe manufacturer's field representative.
2. After the bell or spigot is repaired, all broken mortar or concrete around the repair must be removed and replaced.
3. If the joint ring cannot be repaired, a new ring can be provided by the pipe manufacturer to be butt welded to the damaged one.

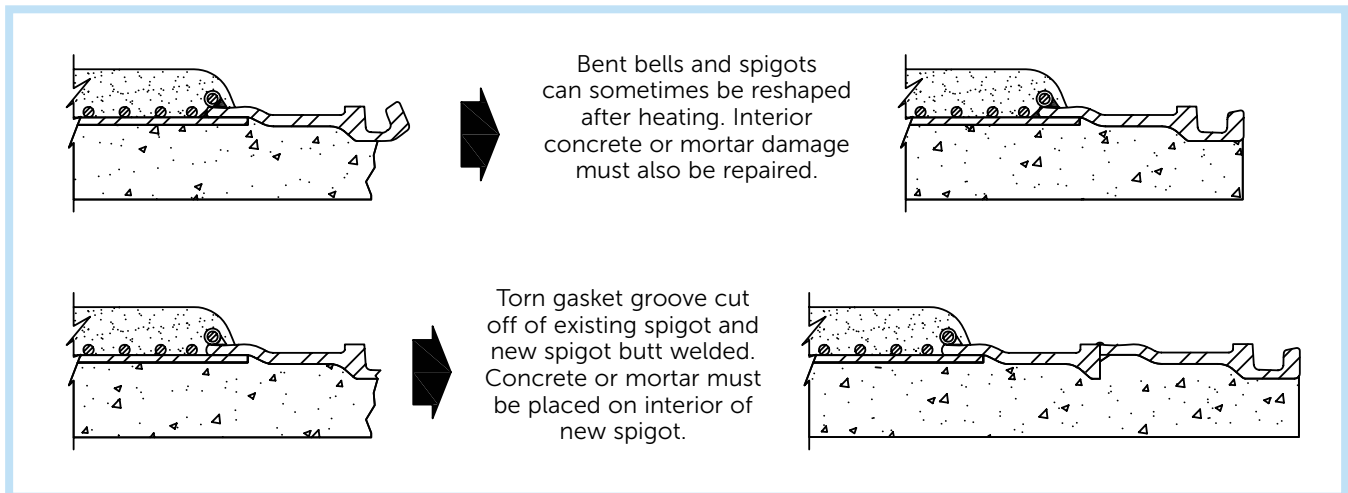

REPAIR PROCEDURES (Cont.)

SPIGOT FIELD ADJUSTMENT

If the looseness is localized and the gasket is in place, the joint can often be sealed by pounding out the spigot with a sledgehammer.

The rubber gasket forms the watertight seal for concrete pressure pipe. As each pipe is laid, a feeler gauge should be used to check the entire circumference of the new joint to assure the seal exists. If there is no seal, the newly engaged pipe should be removed and replaced with another pipe and the new joint checked. If there is still no seal, it may be necessary to remove and repair the previous pipe.

Joints with an excessive gap between the bell and spigot, however, are sometimes not found until many additional pipe have been laid. Such joints are typically identified by dampness from groundwater infiltration.

Suspected loose joints should be inspected with a feeler gauge after removal or before placement of any interior joint mortar. If the looseness of the joint, as indicated with the feeler gauge check, is extensive or if the gasket is cut, missing, or out of place, the joint should be welded for watertightness. However, if the looseness is localized and the gasket is in place, the joint can often be sealed by pounding out the spigot with a sledgehammer.

If the joint can be sealed by pounding out the spigot, a 3" width of mortar or concrete inside the loose area of the joint should be carefully removed. Caution should be exercised to assure the pipe cylinder is not perforated with a chipping gun or similar tool. After the loose area of the spigot is exposed it can be pressed against the mating bell by hammering on the back of the spigot gasket groove.

Intermittently during hammerings the entire joint circumference should be checked with a feeler gauge. If the looseness in the joint begins to move around the joint circumference, the looseness location can be stabilized by placing short ($1/2'' \pm$ long) fillet welds between the bell and spigot on each side of the joint looseness.

Such welds must be placed quickly and immediately cooled with damp rags to avoid burning the gasket. After any necessary welds are placed, the hammering should continue until the joint is found to be tight when checked with a feeler gauge or until it is determined the entire joint must be welded to achieve a seal.

After the joint has been sealed the interior pipe mortar or concrete must be repaired.

SPIGOT FIELD ADJUSTMENT DETAILS

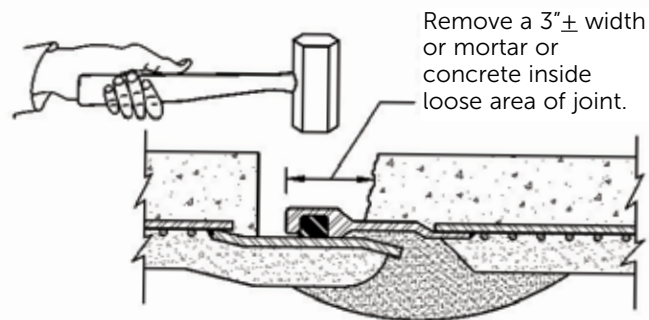
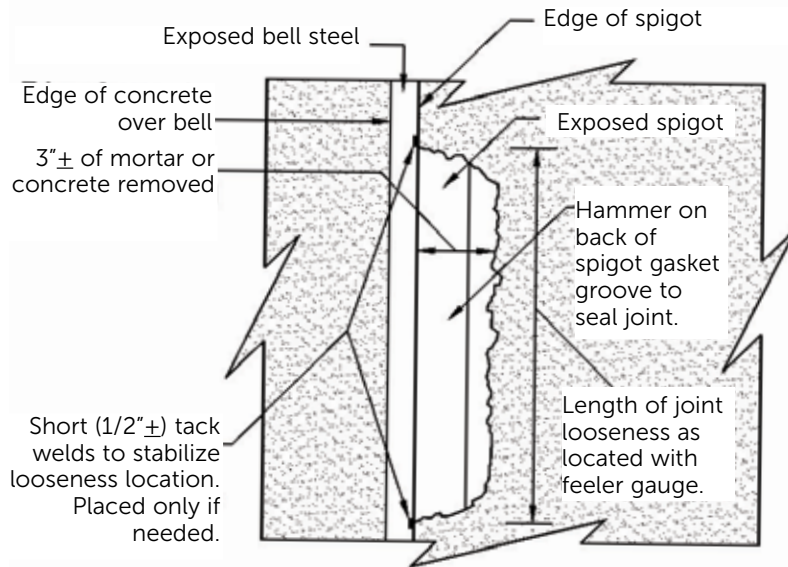

REPAIR PROCEDURES (Cont.)

EXTERIOR JOINT WELD

Repair Procedure

1. Remove sufficient exterior mortar or, for C300 pipe, exterior concrete to provide access for complete circumferential weld. Use caution to avoid breaking any prestressing wire or rod reinforcement.
2. Reduce the gap between materials to be welded. This may require the use of a filler rod or bar, or heating and flattening the bell flare, or similar preparation, depending upon the extent of joint overlap.
3. Place a continuous, watertight weld around the entire circumference of the joint.
4. Repair exterior mortar or concrete.

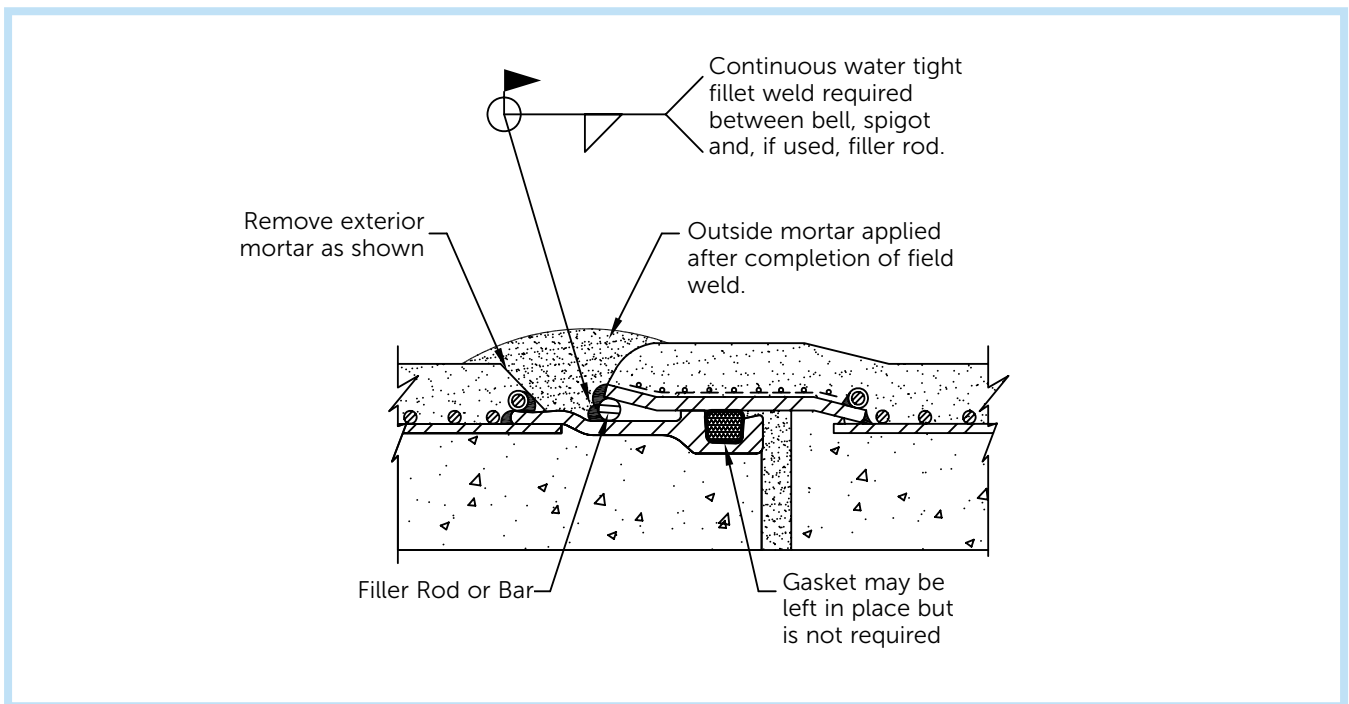

NOTE

The weld must be continuous and watertight, so the gasket is not needed. The joint configuration and need for filler material will vary depending on joint overlap.

INTERIOR JOINT WELD

Repair Procedure

1. The line must be dewatered and access to the interior provided. If no entrance is available, a saddle type manhole can be installed.
2. For repairs required during installation due to insufficient joint overlap, the gasket may be left off the spigot since the weld will be continuous and watertight.
- 3a. To repair joints where the gasket has already been installed, place a fillet weld between the bell and spigot. See Detail A below. The first pass should be fast, "downhill", and may need to be intermittently cooled with a wet rag to minimize smoke from the gasket. Alternatively or if needed, place a 3/8" (9 mm) mild steel rod around the joint and weld solid.
- 3b. Alternatively, place the prefabricated, segmented rings as shown in Detail B and weld in place using watertight welds. Weld "downhill" or skip weld as necessary when welding to the pipe bell to prevent smoke from burning gasket. Butt-weld segment ends together.
4. When the weld is completed, clean the interior joint recess and repair the interior concrete and mortar.
5. Examine the adjacent interior joints to assure they do not need to be welded or re-mortared. Where re-mortaring is required, the exterior should be examined and re-mortared if necessary.

INTERIOR JOINT WELD, DETAIL A

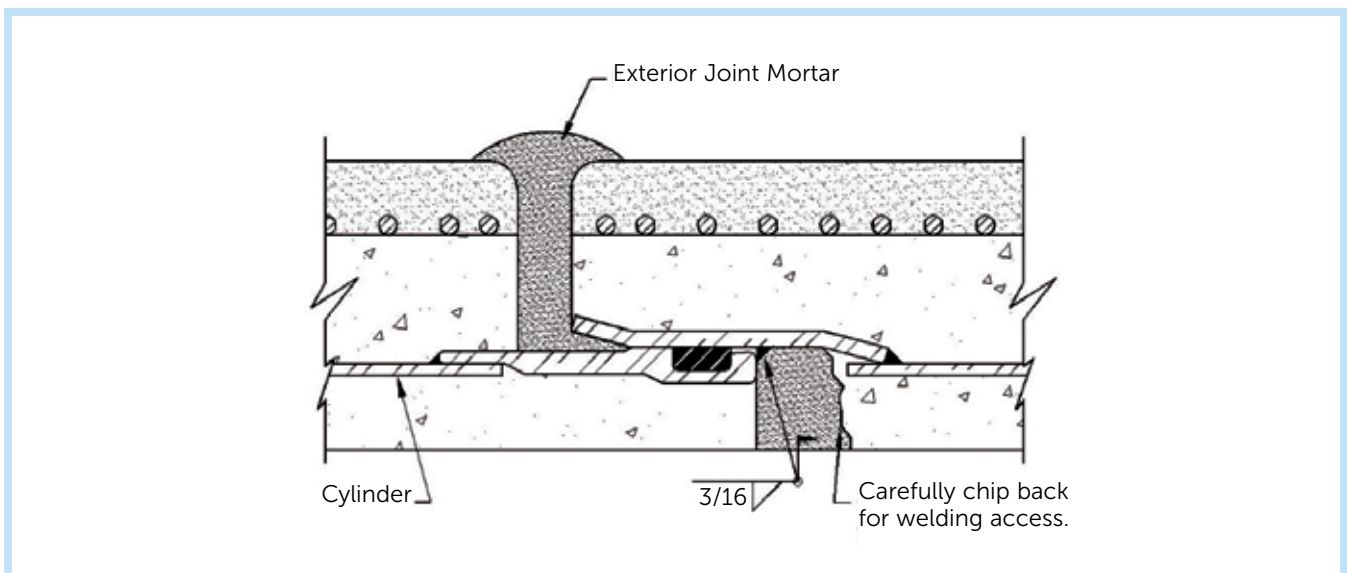

NOTE

The weld must be continuous and watertight.

REPAIR PROCEDURES (Cont.)

INTERIOR JOINT WELD, DETAIL B

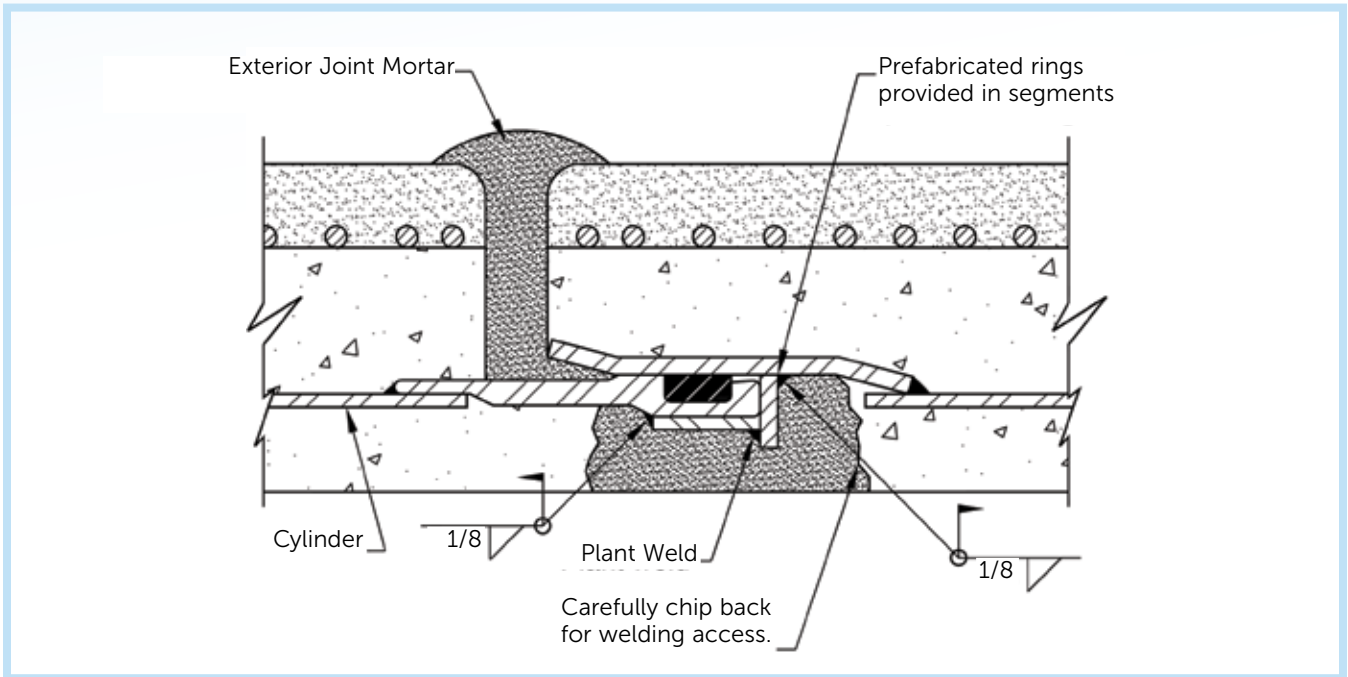

NOTE

The weld must be continuous and watertight.



ACPPA Headquarters
T 714.801.0298
email: support@acppa.org
www.acppa.org