

EXTERNAL PROTECTION

OF CONCRETE CYLINDER PIPE

Guidelines for
Supplemental Protection of
Pipelines in Adverse Environments
for Owners or Specifiers

PUBLISHED: July 2011



DURABLE
ECONOMICAL
ADAPTABLE
RELIABLE
SUSTAINABLE



CONCRETE CYLINDER PIPE has consistently demonstrated longevity and reliability when properly installed in most natural environments. This performance record is attributable to the inherent protection provided by the high pH of portland cement-rich mortar, concrete and slurry which passivate the embedded steel components.

This manual has been developed by the American Concrete Pressure Pipe Association to provide the specifier or owner with helpful guidelines for the supplemental protection of concrete cylinder pipe if it is to be installed in adverse environments.

While it is the belief of the Association that this material represents good practice, the manual should be used as a reference guideline to help readers evaluate their own requirements and specifications. This publication is provided with the understanding that the publisher is not engaged in rendering engineering or other professional services. This manual should not be considered an acceptable substitute for case-specific technical advice. If engineering or other expert assistance is required, the services of a competent professional person should be sought.

ACPPA hereby excludes any and all expressed and implied warranties with respect to this manual and the information contained herein, including fitness for particular purpose and merchantability. Use of this manual constitutes acceptance of these terms.



TABLE OF CONTENTS

4 TYPES OF CONCRETE CYLINDER PIPE

- 4 Prestressed Concrete Embedded-Cylinder Pipe
- 4 Prestressed Concrete Lined-Cylinder Pipe
- 7 Bar-Wrapped Concrete Cylinder Pipe
- 7 Reinforced Concrete Cylinder Pipe

7 CORROSION RESISTANCE OF CONCRETE CYLINDER PIPE

8 PROTECTION OF CONCRETE CYLINDER PIPE IN ADVERSE ENVIRONMENTS

- 8 High-Chloride Environments
- 8 Stray Current Interference
- 9 High-Sulfate Environments
- 10 Severe Acid Conditions
- 10 Long-Term Atmospheric Exposure
- 10 Connections to Other Pipelines

10 BONDING

13 MONITORING

14 CATHODIC PROTECTION

16 GLOSSARY OF CORROSION TERMS

17 REFERENCES

TYPES OF CONCRETE CYLINDER PIPE

Concrete cylinder pipe is a general designation given to pipe manufactured with a watertight steel cylinder and reinforcing or prestressing wire embedded in a portland cement-rich concrete or mortar. The four types of concrete cylinder pipe most commonly produced are:

Prestressed Concrete Embedded-Cylinder Pipe (AWWA C301)

Prestressed concrete embedded cylinder pipe is constructed with steel bell-and-spigot joint rings welded to opposite ends of a steel cylinder which is embedded in concrete. The core assembly is helically wrapped with high tensile strength prestressing wire which is then encased in a cement-rich mortar coating. A slurry coating of portland cement is applied while wrapping the core with prestressing wire, and again while applying the mortar coating. Field installation results in a watertight joint by compressing the rubber gasket between the bell and the spigot sections. *(See Figure 1)*

Prestressed Concrete Lined-Cylinder Pipe (AWWA C301)

Prestressed concrete lined-cylinder pipe is constructed with steel bell-and-spigot joint rings welded to opposite ends of a steel cylinder which is lined on the inside with concrete. The core assembly is helically wrapped with high tensile prestressing wire which is then encased in a cement-rich mortar coating. A slurry coating of portland cement is applied while wrapping the core with prestressing wire, and again while applying the mortar coating. Field installation results in a watertight joint. *(Figure 2)*

Figure 1

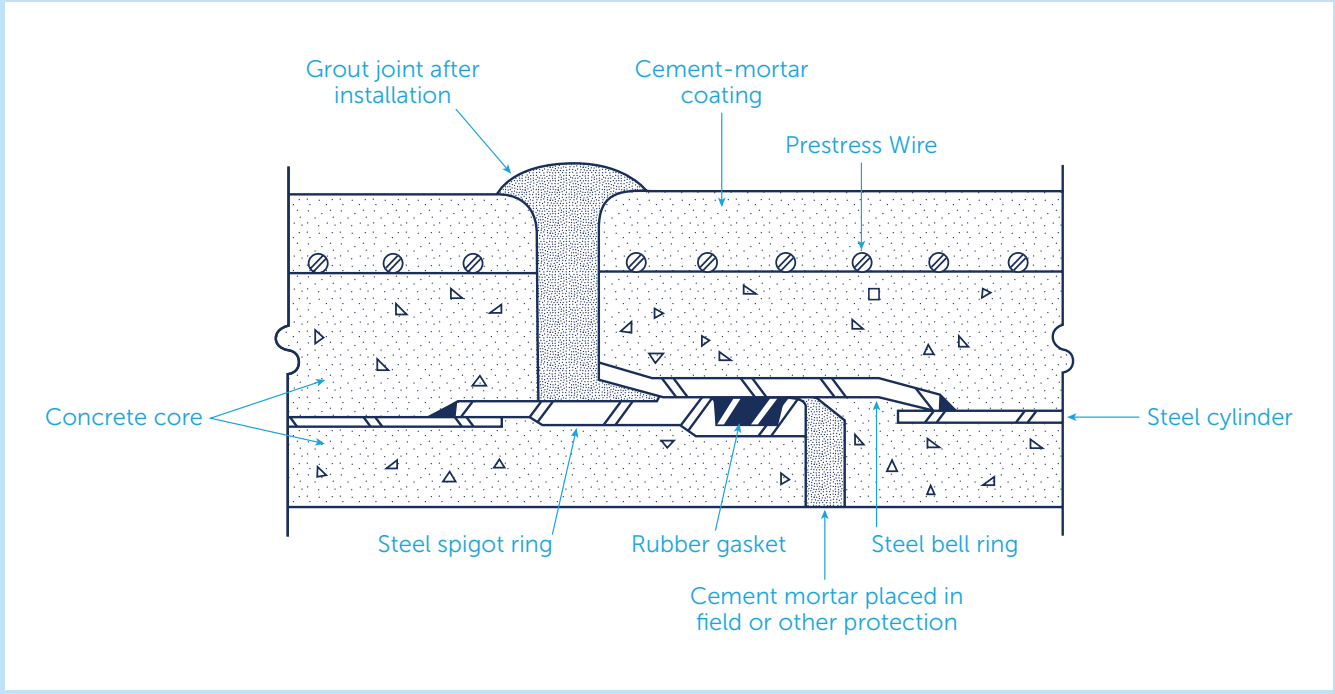

Prestressed Concrete Embedded-Cylinder Pipe. Reprinted from Concrete Pressure Pipe, M9, by permission. Copyright © 2008, American Water Works Association.

Figure 2

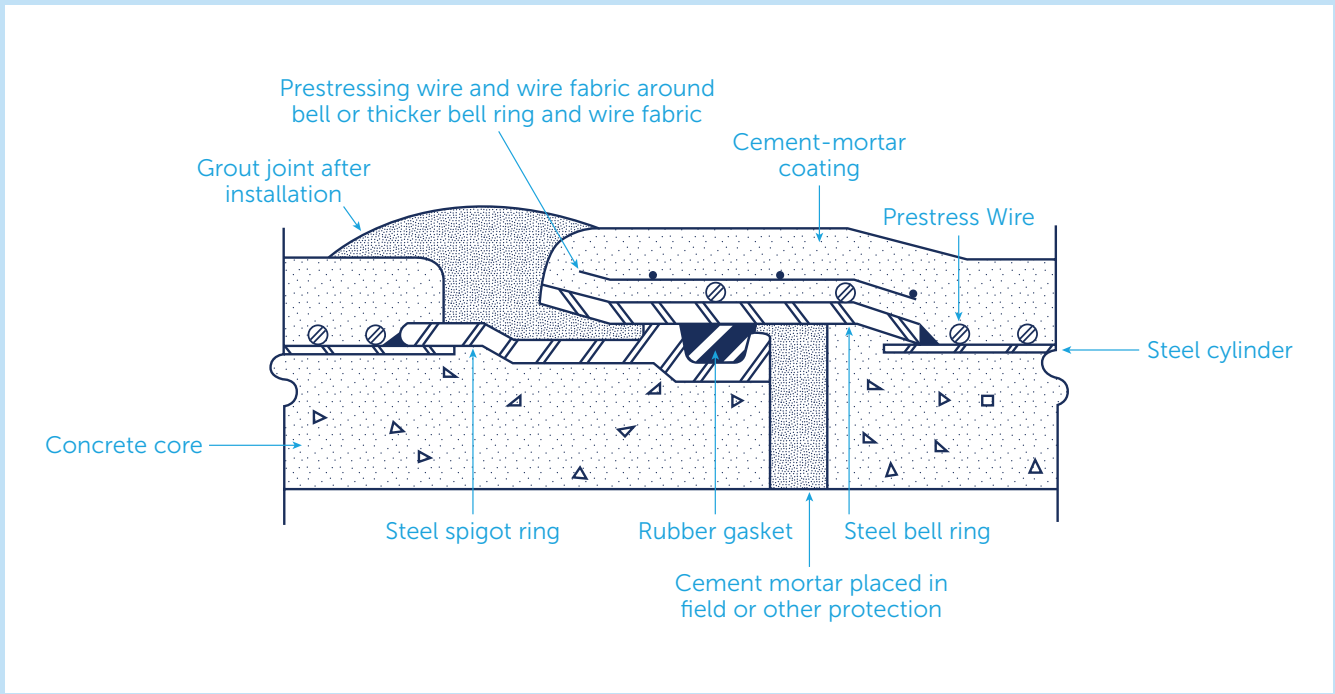

Prestressed Concrete Lined-Cylinder Pipe. Reprinted from Concrete Pressure Pipe, M9, by permission. Copyright © 2008, American Water Works Association.

Figure 3

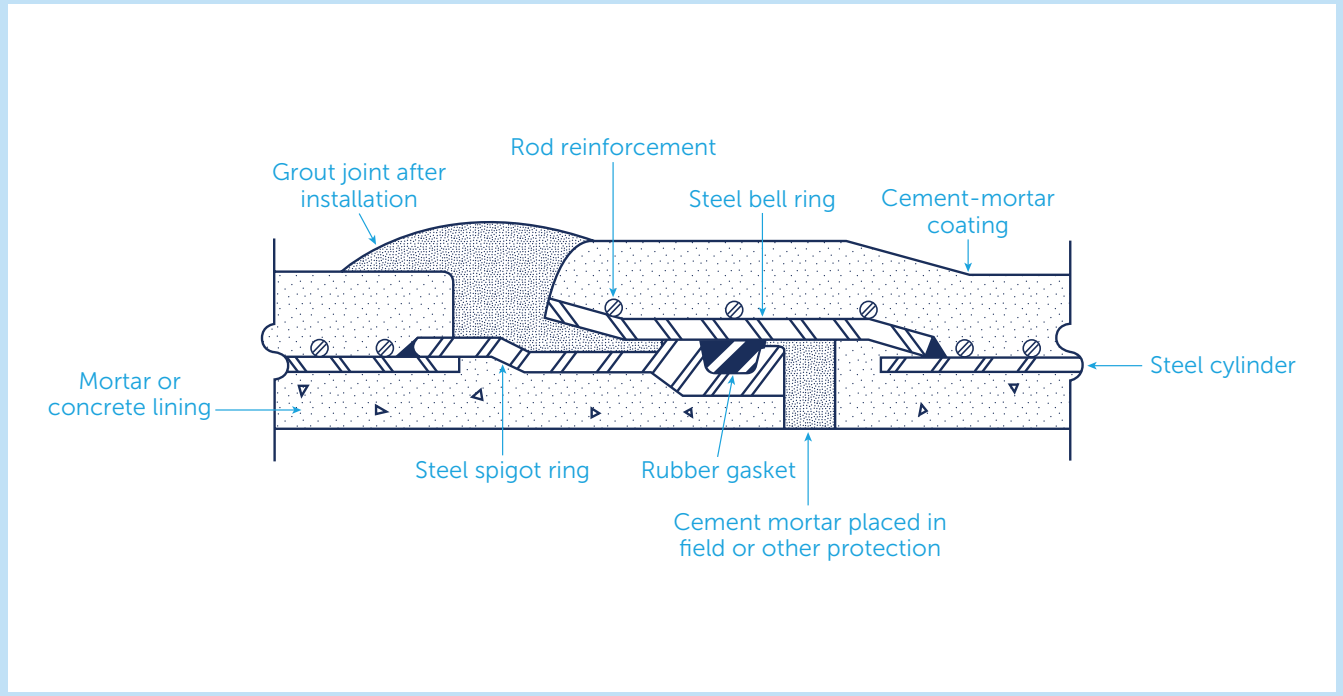

Bar-Wrapped Concrete Cylinder Pipe. Reprinted from *Concrete Pressure Pipe, M9*, by permission. Copyright © 2008, American Water Works Association.

Figure 4

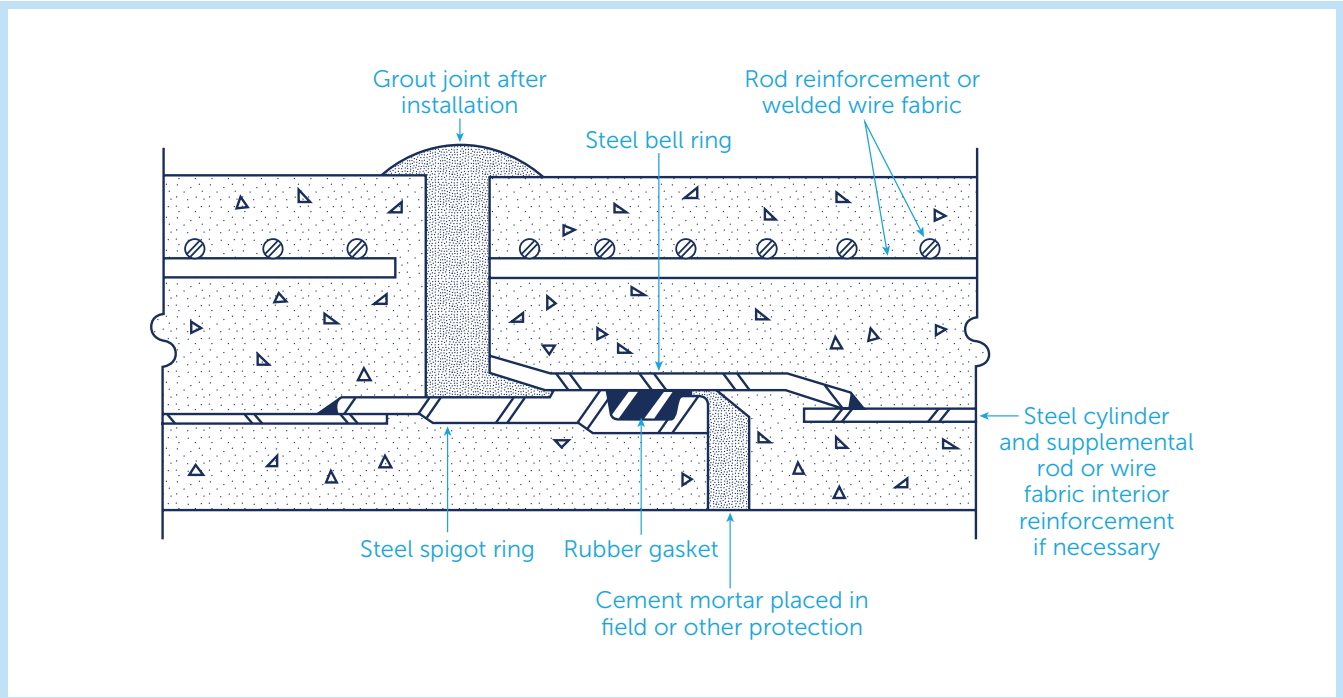

Reinforced Concrete Cylinder Pipe. Reprinted from *Concrete Pressure Pipe, M9*, by permission. Copyright © 2008, American Water Works Association.

TYPES OF CONCRETE CYLINDER PIPE (CONT'D)

Bar-Wrapped Concrete Cylinder Pipe (AWWA C303)

Bar-wrapped concrete cylinder pipe is constructed with steel bell-and-spigot joint rings welded to opposite ends of a steel cylinder. A centrifugally cast mortar or concrete lining is placed inside the cylinder. The assembly is then helically wrapped with mild steel rod and an exterior cement mortar coating is applied. A slurry coating of portland cement is applied while wrapping the assembly with steel rod and again while applying the mortar coating. *(Figure 3)*

Reinforced Concrete Cylinder Pipe (AWWA C300)

Reinforced concrete cylinder pipe is constructed with steel bell-and-spigot joint rings welded to opposite ends of a steel cylinder. The steel cylinder and one or more reinforcing cages are cast into a concrete wall. *(Figure 4)*

CORROSION RESISTANCE OF CONCRETE CYLINDER PIPE

Concrete cylinder pipe provides trouble-free service when properly installed in most environments. Corrosion protection is provided to the embedded steel elements of the pipe by the high alkalinity of hydrated portland cement, which has a pH in the range of 12.5 to 13.5. At that pH, a passivating oxide film forms and is maintained on embedded steel surfaces, which precludes the possibility of electrochemical corrosion, except in adverse environments.

In the absence of an external impressed voltage, passivated steel in concrete has a potential ranging from approximately 0 to -200mV to a copper-copper sulfate reference electrode. That potential is 300 to 500 mV more noble than the potential of bare or dielectrically-coated steel. Any significant shift in the potential of steel in concrete away from the passive range is an indication of possible corrosion activity or stray current interference. The unique potential of passivated steel in concrete makes it possible to monitor potentials along concrete cylinder pipelines to determine corrosion activity. In order to do this monitoring, the pipeline must be electrically continuous. *(See Bonding and Monitoring)*

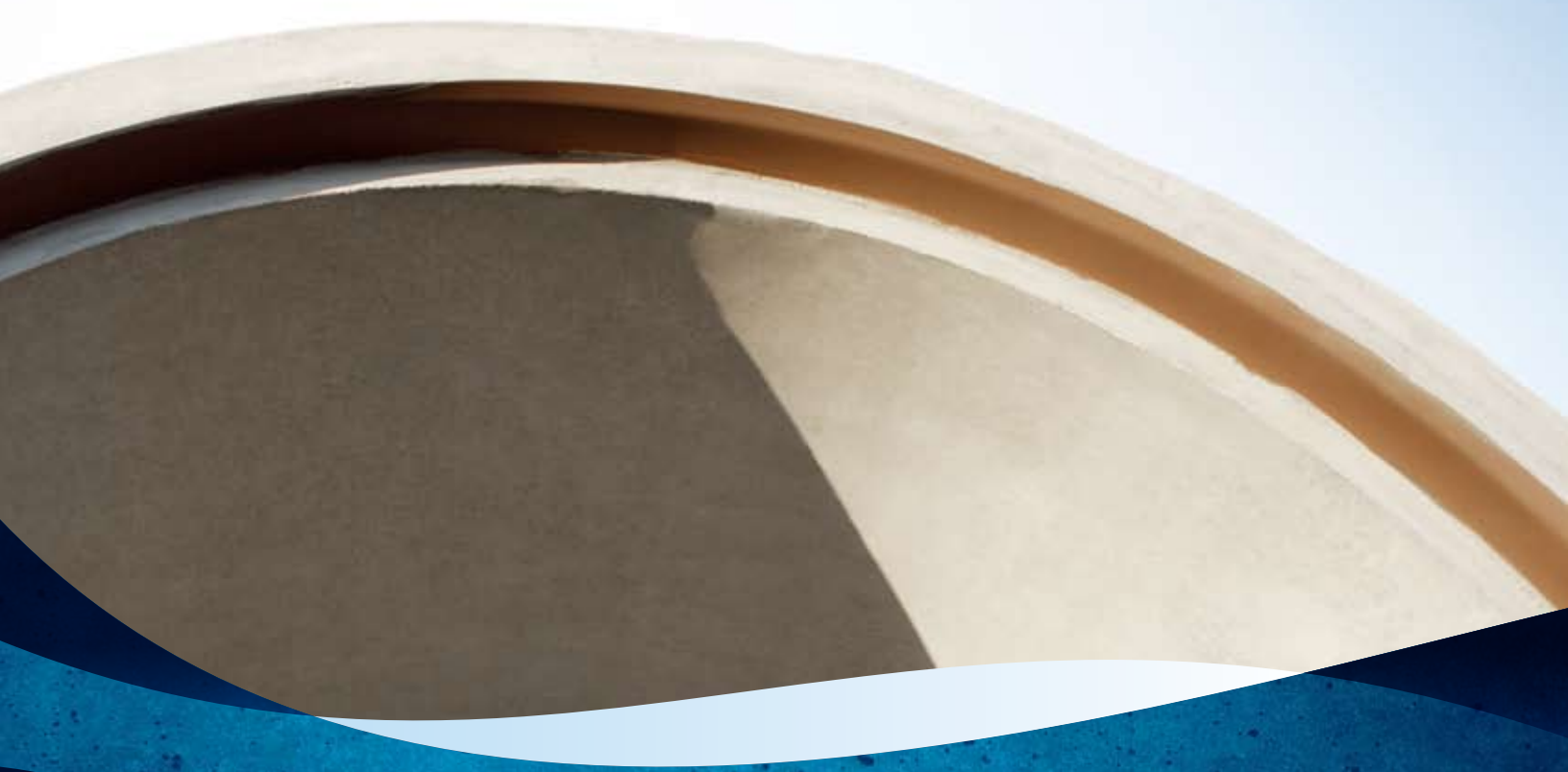

PROTECTION OF CONCRETE CYLINDER PIPE IN ADVERSE ENVIRONMENTS

In most installation environments, no supplemental corrosion protection is required for concrete cylinder pipe. Adverse environmental conditions, where precautionary measures may be necessary to ensure pipeline integrity, are:

- High-chloride environments
- Stray current interference
- High-sulfate environments
- Severe acid conditions
- Long-term atmospheric exposure

Soil resistivity can give an indication that high concentrations of chloride, sulfate, or other ions may be present. Because it is easier to measure soil resistivity than soil chemistry, it is recommended that a soil resistivity survey be performed along the pipeline right-of-way to locate potentially adverse conditions. Where soil resistivity is less than 1,500 ohm-cm, soil chemistry should be analyzed.

High-Chloride Environments

In order to initiate corrosion, a sufficiently high concentration of chloride ions, in combination with oxygen at the steel surface, is required to disrupt the passivation of steel embedded in concrete or mortar. However, the amount of corrosion will be limited unless the oxygen at the steel surface can be replenished.

For example, in pipelines continuously submerged in fresh water or seawater, the embedded steel in concrete cylinder pipe does not experience damaging corrosion, even in seawater that contains approximately 20,000 ppm chloride ion, due to the extremely low rate of oxygen diffusion through the saturated mortar coating. As a result, supplemental protection over the mortar coating is not required for continuously submerged concrete cylinder pipe. However, a protective coating system should be applied to the exposed portions of the steel joint rings unless they will be encased in portland cement mortar or grout.

On the other hand, concrete cylinder pipe that is buried in soils with significant water-soluble chloride concentrations must be evaluated differently. If pipe is to be buried in soils with resistivity readings below

1500 ohm-cm and the water-soluble chloride content exceeds 400 ppm at those same locations, one of the following protective measures should be used:

- A moisture barrier should be used to protect the exterior surfaces;
- Silica fume in an amount equal to 8 to 10 percent of the cement weight or a corrosion inhibitor should be included in the exterior mortar or concrete; or
- Cathodic protection should be installed if monitoring of the pipeline detects the onset of corrosion.

Stray Current Interference

Stray current interference from nearby sources of direct current, such as impressed-current cathodic protection systems and electric railway or subway systems, may be picked up and discharged by buried metallic pipelines. An example of interference from an impressed-current cathodic protection system is shown in *Figure 5*. If stray current discharges from a dielectrically-coated steel pipeline, the discharge will be at pinholes or other flaws in the coating, resulting in corrosion pitting at those locations. If stray current discharges from steel encased in concrete or mortar, it will be distributed over larger surface areas and it will consume excess alkalinity before corroding the steel. Due to those mitigating factors, concrete cylinder pipelines can tolerate stray current interference without the initiation of corrosion for a longer time than dielectrically-coated steel pipe. When stray current interference is anticipated or known to exist, one of the following measures should be considered for concrete cylinder pipe:

- Eliminate the source of the stray current if possible;
- Apply a supplemental barrier with dielectric properties to the pipe exterior to increase the pipe's electrical resistance; or
- Provide electrical continuity bonding and monitor the pipeline after installation to determine if stray current is being picked up or discharged. If stray current is picked up, provide the means to safely discharge it.

Figure 5

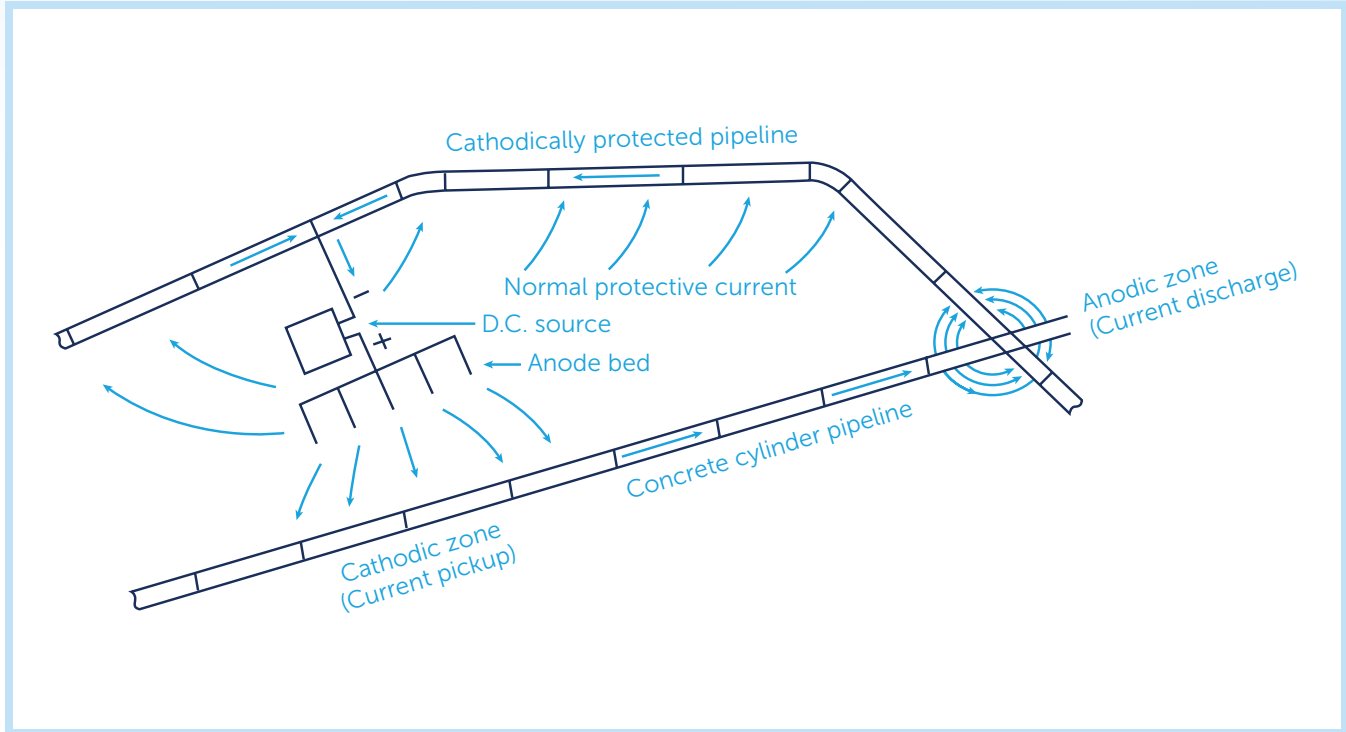

Example of stray current interference from an impressed-current cathodic protection system.

High-Sulfate Environments

Soils with high concentrations of sodium, magnesium, or calcium sulfates are frequently referred to as alkali soils. These soils can chemically attack concrete structures, but such attacks are generally limited to partially buried structures where capillary action and surface evaporation can build up high sulfate concentrations in the concrete or mortar. Completely buried concrete pipelines are not normally subject to sulfate build-up. Also, the high cement content typical of the exterior mortar coating or concrete on concrete cylinder pipe (6 to 10 sacks per cubic yard) has been shown to significantly increase sulfate resistance. In addition, a sufficiently low permeability of the placed concrete or mortar has been shown to drastically reduce sulfate attack, such that even high tricalcium aluminate (C_3A) cements can be used to make concretes or mortars with good sulfate resistance.

As a result, sulfate attack on completely buried concrete pipelines is extremely rare. However, exposed or partially exposed concrete pipelines in or on high sulfate soils require protective measures. In these cases, when the water-soluble sulfate content of the soil is 2,000 ppm or less, standard Type II portland cement should be used. If the soil contains more than 2,000 ppm water-soluble sulfates, a portland cement with a C_3A content of 5 percent or less or silica fume in an amount equal to 8 to 10 percent of the cement weight should be used. Alternatively, instead of special cement or the addition of silica fume, a barrier material can be used to isolate the pipe exterior from the sulfates.

Severe Acid Conditions

Chemical attack of the exterior of concrete pressure pipe in acidic soils is rare and usually limited to unnatural conditions such as mine wastes, acid spills or industrial dumps. Such conditions often involve mineral acids, such as sulfuric acids, with very low pH and high total acidity values. In poorly drained soils, any acid groundwater in contact with the pipe exterior is neutralized by the alkalinity of the mortar or concrete and is slow to be replaced. Therefore, in soils such as fine-grained silts or clay, where replenishment is greatly reduced by the imperviousness of the soil, supplemental protection against acid conditions is not normally necessary. If acidic soils are granular, replenishment of acidity at the pipe surface is more easily accomplished.

Guidelines for evaluating the aggressiveness of acidic soils and the need for supplemental protection are as follows:

1. In granular soils, when pH measured on the soil sample is below 5, the total acidity should be determined. If the total acidity exceeds 25 meq/100 gm of dry soil, one of the following precautions should be used:
 - Backfill the pipe zone with consolidated clay material;
 - Backfill the pipe zone with calcareous material;
 - Install an acid-resistant membrane on or around the pipe; or
 - Add silica fume in an amount equal to 8 to 10 percent of the cement weight to the mortar coating.
2. Where soil pH is below 4, the pipe should be installed in an acid-resistant membrane or in an envelope of nonaggressive consolidated clay.

Long-term Atmospheric Exposure

Pipe installed above ground is subjected to a different environment than buried pipe. Above-ground lines will be exposed to large temperature fluctuations, wetting and drying cycles, atmospheric carbonation, and possibly freezing and thawing cycles that, over a long period of time, can detrimentally affect the protective properties of the exterior concrete or mortar coating. For such installations, a light-colored barrier coating over the

pipe exterior may be used initially and periodically renewed, if deemed necessary to maintain the integrity of the underlying concrete or mortar coating.

Connections to Other Pipelines

Because the potential of steel encased in concrete or mortar is 300 to 500 mV less negative than bare or dielectrically-coated iron or steel, when a connection is made between a concrete cylinder pipe and bare or dielectrically-coated iron or steel pipe, the concrete pipe may be protected by sacrificial corrosion of the ferrous pipe. In most cases, the problem is inconsequential. However, if the problem is to be completely eliminated, an insulating connection should be used in joining the concrete pipe to the ferrous pipe, or the ferrous pipe should be encased in concrete or mortar to bring both pipe materials to the same potential.

BONDING

If monitoring is planned or the application of cathodic protection is a possibility, concrete cylinder pipe with electrical continuity bonding must be provided. For concrete cylinder pipe, electrical continuity between pipe sections is usually provided by field welding a steel clip, steel bar or stranded copper cable to both steel joint rings after joint assembly. Typical details of joint bonds for the three common types of concrete cylinder pipe are shown in *Figures 6 and 7*.

Electrical continuity of the steel elements within each pipe section is inherent for Prestressed Concrete Lined-Cylinder Pipe (AWWA C301) and for Bar-Wrapped Concrete Cylinder Pipe (AWWA C303) pipe due to the direct contact of the wire or bar wraps and the steel cylinder. For AWWA C301 embedded-cylinder pipe with bonded joints, a mild steel shorting strap is placed on the exterior of the core in the plant prior to wrapping with prestressing wire. The contact of each wire wrap with the shorting strap reduces the electrical resistance of the pipe segment by several times when compared to pipe segments without shorting straps. Low resistance is important if stray current mitigation or cathodic protection is needed. The shorting strap is shown in *Figure 6*. For AWWA C300 pipe, a shorting strap is not required, but an electrical continuity connection between the cage(s) and the steel cylinder should be provided at each end of the pipe.

Figure 6

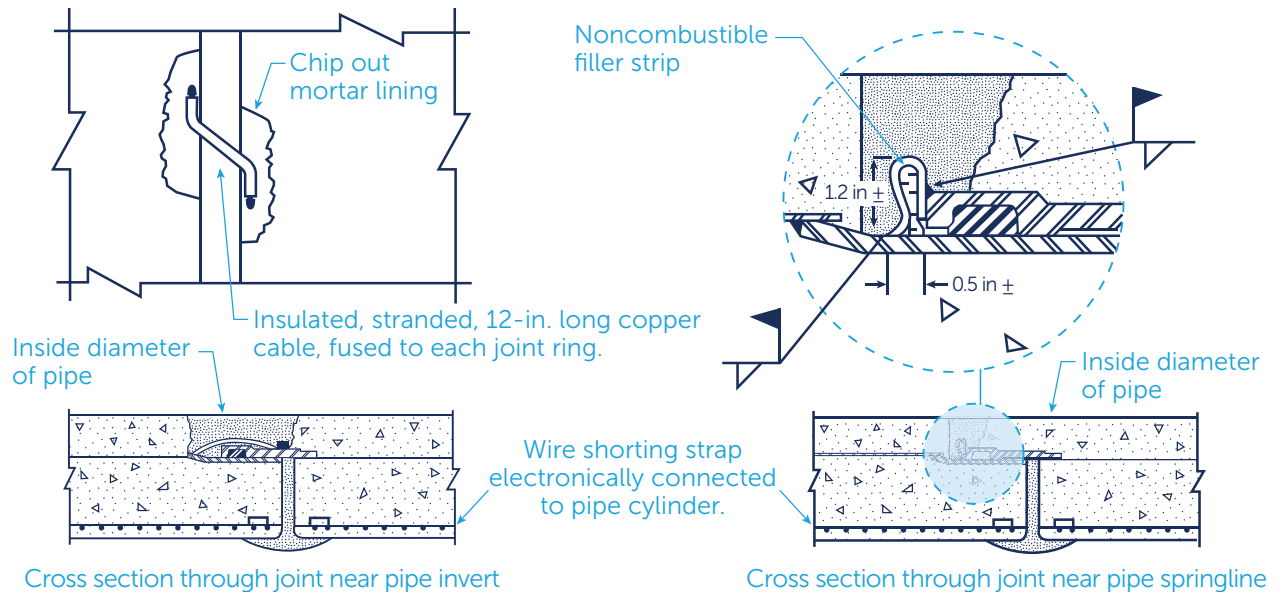

A. Bonding Cable on Inside

B. Bonding Clip

Thickness = 0.134 in. ±
Width = 1.25 in. ±

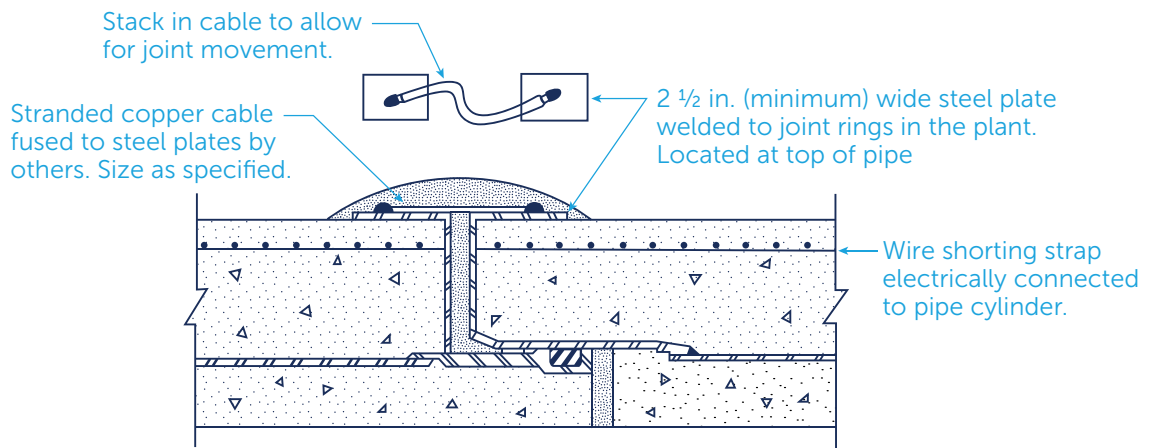

C. Bonding Cable on Outside

When bonding inside the pipe as shown in Diagrams A and B of Figure 6, recesses in the lining of the concrete core are chipped as required after pipe field assembly, or are blocked out during pipe manufacture. All recesses are then filled with cement mortar. When bonding from the outside, as shown in Diagram C of Figure 6, the bonding cable is welded to the angle-shaped clips and encased in the exterior joint grout.

Typical bonded joints for AWWA C301 embedded cylinder pipe. Reprinted from *Concrete Pressure Pipe, M9*, by permission. Copyright © 2008, American Water Works Association.

Figure 7

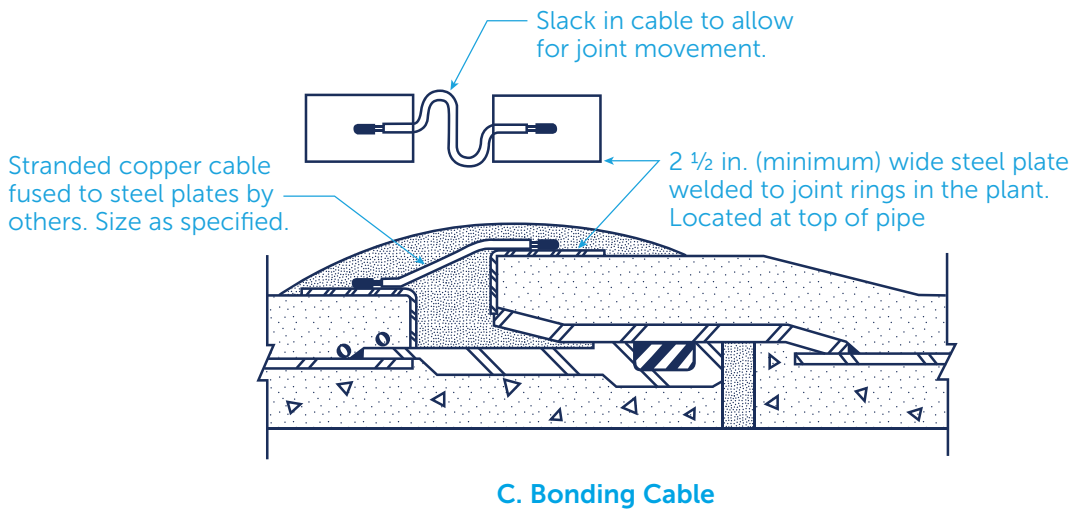
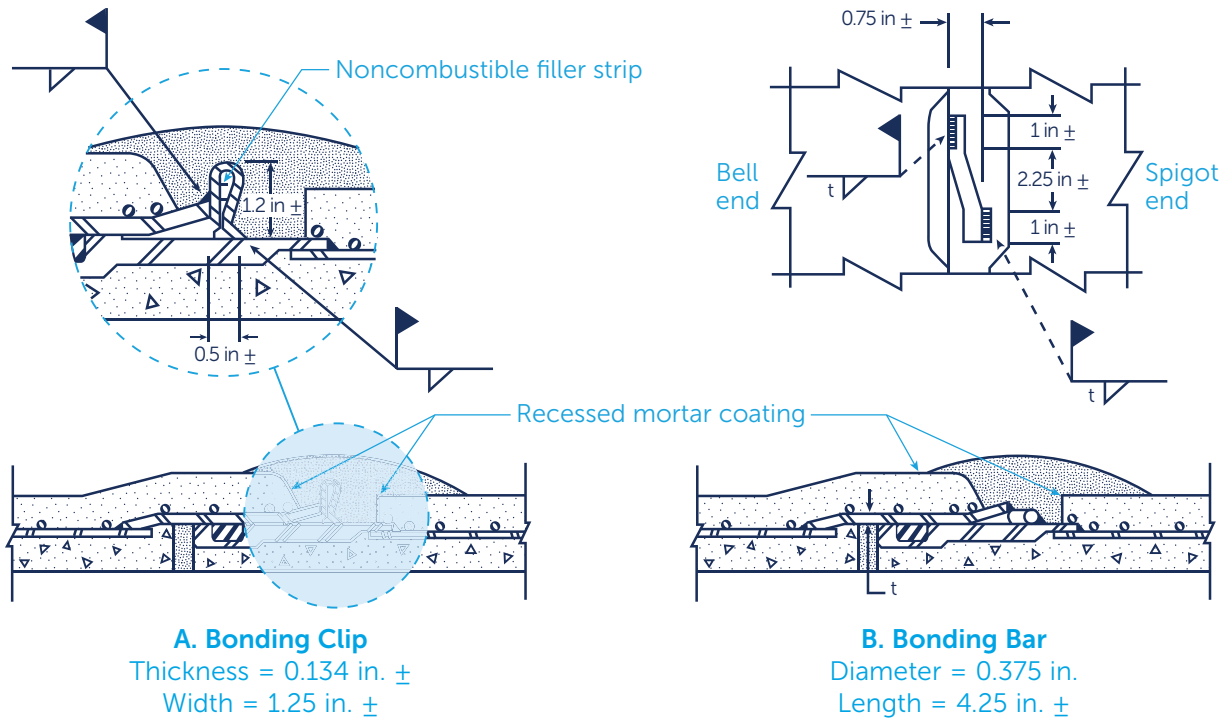

The bonding methods shown provide electrical conductivity across the joint and accommodate relative movement due to pipeline settlement. To provide access for welding the bonds, as shown in Diagrams A and B, recesses are chipped in the mortar coating as required after field assembly. Separate bonding is not required when joints are field welded.

Typical bonded joints for AWWA C301 lined-cylinder pipe or AWWA C303 pipe. Reprinted from Concrete Pressure Pipe, M9, by permission. Copyright © 2008, American Water Works Association.

MONITORING

It is good engineering practice to periodically monitor the electrical potential of all buried pipelines having metallic components to determine if electrochemical conditions exist that could detrimentally affect the performance of the pipeline. By periodically monitoring the pipeline, corrosion activity can be detected and remedial action taken before significant damage occurs.

Potentials reflect electrochemical reactions occurring on metal surfaces in the pipeline and are measured against a standard reference electrode. A copper-copper sulfate electrode is commonly used for pipeline surveys. Potentials should be measured at close intervals, equally spaced along the pipeline to avoid missing unusual conditions. Spacing intervals of three to ten feet are commonly used.

In the absence of stray currents or cathodic protection, pipeline potentials within 0 to -200 mV (CSE) indicate the pipeline is free of damaging corrosion. There are several possible indications of corrosion activity, including potentials that are more negative than -350 mV, large variations in potentials along the pipeline, and long-term trends towards more negative potentials.

A decision to periodically monitor pipelines requires that initial design and construction should include provisions that make all metallic components of the pipeline electrically continuous.

A decision to monitor a pipeline also requires a commitment by the owner to establish a periodic monitoring program. If a line is not monitored, an owner is unlikely to realize the full benefits from the added initial cost of making a pipeline electrically continuous. In addition, there is a possibility that corrosion-related problems on a bonded pipeline, if they occur, may progress at a rate faster than on an un-bonded pipeline.

There are some limitations in monitoring for corrosion activity on any pipeline:

- The soil surface must be adequately moist to obtain meaningful readings.

- Monitoring potentials cannot be taken through asphalt pavement. When readings are to be taken in paved areas, it is necessary to drill small holes through the pavement to permit the reference electrode to be in contact with moist soil or to place the reference cell on unpaved soil near the pipeline.
- Stray currents or impressed direct currents affect potential measurements. Currents collecting on the pipeline make measured potentials more negative; discharging currents make potentials more positive.
- Potentials of electrically connected dielectrically-coated steel pipelines or ferrous appurtenances are more negative than potentials of concrete or mortar-coated steel, and can therefore appear as corrosion sites on a concrete pipeline.
- For proper interpretation of the readings, it is essential to know of the existence and location of other underground structures (tanks, pipelines, etc.) in the vicinity and appurtenances (valves, branch outlets, etc.) on the pipeline being monitored.

An effective monitoring program starts by taking an initial set of readings about one year after the pipeline is installed. Time intervals between subsequent surveys are usually established after evaluating the results of prior surveys. Changes in the vicinity of the pipeline such as new construction, implementation of cathodic protection on other structures, or adjustments in existing cathodic protection systems on other structures may necessitate surveys sooner than otherwise scheduled. Significant changes in the readings at a particular location over time, or significant differences in the readings at one location compared with readings at adjacent or nearby locations, may be indicative of damaged mortar/concrete, corrosion or stray current interference. A qualified corrosion engineer, experienced in the protection of concrete pressure pipe, is important not only for conducting monitoring surveys but also for interpreting the readings.

CATHODIC PROTECTION

Concrete cylinder pipe rarely requires cathodic protection because of the corrosion protection provided by the alkalinity in the portland cement concrete or mortar coating. Cathodic protection should not be applied indiscriminately. Should monitoring or other pipeline investigation indicate the likelihood of corrosion in a concrete cylinder pipeline, the area in question should be excavated to permit visual examination of the pipe if at all possible. Frequently, monitoring potentials indicative of corrosion are caused by corrosion of appurtenances in the pipeline such as valves or branch lines connected to the concrete cylinder pipe. Should corrosion be found on the concrete pipe, repair or replacement of the affected pieces should be a first consideration. If this is not possible, cathodic protection can be applied to the affected portion of the pipeline to mitigate further corrosion.

When cathodically protecting prestressed concrete cylinder pipe, it is very important that the maximum current-interrupted potential be less negative than $-1,000$ mV to a copper/copper sulfate reference electrode to avoid formation of atomic hydrogen and possible embrittlement of prestressing wire. A minimum 100 mV shift in potential should be used to cathodically protect steel in concrete. Even if corroding, concrete cylinder pipelines still have the vast majority of the steel surfaces passivated by mortar or concrete. As a result, the current density requirements to provide cathodic protection are far less than would be needed if all steel surfaces were bare. To achieve the minimum 100 mV shift,

current density requirements for concrete cylinder pipe can be expected to fall within the range of 10 to 100 micro amps per square foot of the pipe's outside surface area. If the concrete cylinder pipe has an exterior dielectric membrane or barrier coating, the 100mV shift with current densities of less than 10 micro amps per square foot can be expected.

For the limited conditions where cathodic protection of concrete cylinder pipe is required, use of sacrificial galvanic anodes is usually more economical. Such a system has other advantages over an impressed current system. Galvanic anodes:

- are unlikely to cause stray current interference problems on nearby structures;
- are unlikely to cause hydrogen evolution; and
- require less frequent monitoring, maintenance, and adjustment.

Regardless of the system used, cathodic protection should be designed, operated, and monitored by qualified technical personnel.

CHART OF CORROSION CONDITIONS AND POSSIBLE SOLUTIONS

CONDITION	CRITERION/CONCERN	POSSIBLE SOLUTIONS (only one solution required)
HIGH CHLORIDES IN SOIL	$< 1500 \Omega\text{-cm}$ and $\text{Cl}^- > 400 \text{ ppm}$	<ul style="list-style-type: none"> Moisture barrier Silica fume in exterior mortar coating or concrete Corrosion inhibitor in exterior mortar coating or concrete Cathodic protection if corrosion present
STRAY CURRENT	Anticipated/exists	<ul style="list-style-type: none"> Supplemental dielectric barrier Bond and monitor Cathodic protection application
HIGH SULFATES IN SOIL	$\text{SO}_4^{2-} < 2000 \text{ ppm}$ $\text{SO}_4^{2-} > 2000 \text{ ppm}$	<ul style="list-style-type: none"> ASTM C150 Type II portland cement $\text{C}_3\text{A} \leq 5\%$ in portland cement for exterior mortar coating or concrete Silica fume in exterior mortar coating or concrete Barrier material
SEVERE ACID CONDITIONS	In granular soils, $\text{pH} < 5$, and total acidity $> 25 \text{ meq per } 100 \text{ grams soil}$ $\text{pH} < 4$	<ul style="list-style-type: none"> Clay backfill Calcareous backfill Supplemental barrier Silica fume in mortar coating or concrete Clay backfill Supplemental barrier
ATMOSPHERIC EXPOSURE	<ul style="list-style-type: none"> Large temperature fluctuations Wetting & drying cycles Solar radiation Atmospheric carbonation Freezing & thawing 	<ul style="list-style-type: none"> Light colored barrier coating

GLOSSARY OF CORROSION TERMS

The definitions of the corrosion terms listed here are consistent with their use in this document.

ANODE: The electrode of an electrochemical cell in which the loss of electrons (and generally loss of metal ions) occurs. (See definition of Electrochemical Cell).

BONDING: The process of making a portion of buried pipeline electrically continuous by tying together all steel elements of an individual pipe length and providing low resistance field connections across each pipe joint.

CALCAREOUS: Material containing compounds of calcium; particularly calcium carbonate. Limestone is an example of a calcareous material.

CARBONATION: The chemical reaction of calcium hydroxide (in cement) with carbon dioxide. The primary product of this reaction is calcium carbonate.

CATHODE: The electrode of an electrochemical cell in which the gain of electrons occurs. Loss of metal does not generally occur at the cathode. (See definition of Electrochemical Cell).

CATHODIC PROTECTION: The mitigation of corrosion by the application of an external potential opposite to the direction of the corrosion activity.

COPPER-COPPER SULFATE ELECTRODE (CSE): A reference electrode used in conjunction with a high impedance voltmeter to determine pipe-to-soil potentials in a buried pipeline.

CURRENT-INTERRUPTED POTENTIAL: The measured potential of the buried pipeline when the cathodic protection system is momentarily deactivated.

ELECTROCHEMICAL CELL: An electrolytic cell containing four principal components: an anode, a cathode, an electrolyte, and a current path. In an electrochemical cell, direct current will flow from the anode to the cathode due to a potential difference between the two electrodes.

MONITORING: The process of determining corrosion activity in a buried pipeline through periodic electrical surveys.

pH: A measure of the hydrogen ion activity or intensity in an electrolyte. The lower the pH value, the more acidic the medium will be.

PASSIVATION: The reduction of the anodic reaction rate for steel embedded in portland cement mortar due to chemical reactions occurring on the metallic surface that create counter or polarization potentials.

PIPELINE POTENTIAL: The electrical potential between the metallic components of a pipeline and a reference electrode, a determination made by monitoring. Experienced corrosion engineers can generally determine the corrosion activity of the buried pipeline from these measurements.

REFERENCES

POTENTIAL: The electrical state of material, the units being in volts (V) or more commonly mV (one thousandth of a volt).

RESISTANCE: The tendency of an electrical circuit to retard the flow of current, measured in ohms.

SOIL RESISTIVITY: A measure of the effective resistance of soil to the conduction of electrical current over a unit distance. It is measured in ohm-centimeters.

STRAY CURRENT INTERFERENCE: The unintentional collection or discharge of current in a metallic (or mortar encased) pipeline due to its proximity to an external source of direct current. Generally loss of metal occurs at the discharge (anodic) area while no loss of metal is experienced at the collection (cathodic) area.

"Analysis of Monitoring Techniques for Prestressed Concrete Cylinder Pipe," Sylvia C. Hall, Corrosion '94, Paper No. 510, NACE International Annual Conference and Exposition, Houston, Texas.

"Cathodic Protection of Prestressed Concrete Cylinder Pipe Utilizing Zinc Anodes," Risque L. Benedict and Jerold G. Ott of Corrosion Consulting Service Corporation with David H. Marshall and Dale White of Tarrant County Water Control and Improvement District #1, Corrosion '96, NACE International Annual Conference and Exposition, Houston, Texas.

"Cathodic Protection Requirements of Prestressed Concrete Cylinder Pipe," Sylvia C. Hall and Ivan Mathew, Advances in Underground Pipeline Engineering, Proceedings, Second International Conference, Pipeline Division and TCLEE/ASCE, June 25-28, 1995, Bellevue, Washington.

"Cathodic Protection to Control External Corrosion of Concrete Pressure Pipelines and Mortar-Coated Steel Pipelines for Water or Waste Water Service," NACE International, SP0100-2008.

"Cathodic Protection Studies on Coal Tar Epoxy-Coated Concrete Pressure Pipe," Sylvia C. Hall, E.J. Carlson and R. G. Stringfellow, *Materials Performance*, Vol. 33, No. 10, October, 1994, Houston, Texas.

"Concrete Pressure Pipe," American Water Works Association Manual of Water Supply Practices - M9, Denver, Colorado.

"Corrosion Control" Proceedings, AWWA Seminar on Corrosion Control, Distribution System Symposium, September 8-11, 1985, Seattle, Washington.

"Corrosion Control of Prestressed Concrete Cylinder Pipe," Sylvia C. Hall, Pipelines in the Constructed Environment, Proceedings of the ASCE 1998 Pipeline Division Conference, August 23-27, 1998, San Diego, California.

"Corrosion of Prestressed Wire in Concrete," G.C. Monfore and G.J. Verbeck, *Journal of the American Concrete Institute*, Vol. 32, No. 5, November 1960, Detroit, Michigan.

"Corrosion Protection of Concrete Cylinder Pipe," Risque L. Benedict, Corrosion '89, Paper No. 368, NACE International Annual Conference and Exposition, Houston, Texas.

"Corrosion Protection Criteria for Prestressed Concrete Pipe - An Update," Sylvia C. Hall, Corrosion '98, Paper No. 637, NACE International Annual Conference and Exposition, Houston, Texas, and in *Materials Performance*, Vol. 37, No. 11, Pages. 14 - 21, November 1998.

"Corrosion Protective Properties of Concrete Cylinder Pipe," Risque L. Benedict, Corrosion Control, AWWA Seminar Proceedings, American Water Works Association, 1985, Denver, Colorado.

"Prestressed Concrete Pipe Corrosion Research - A Summary of a Decade of Activities," Sylvia C. Hall, Ivan Mathew and Qizhong Sheng, PhD. of Ameron International, Corrosion '96, Paper No. 330, NACE International Annual Conference and Exposition, Houston, Texas.

"The Corrosion Inhibitive Properties of Cement Mortar Coatings," Gordon N. Scott, Consulting Engineer, 18th Annual Conference of the NACE, 1962, Kansas City, Missouri.



ACPPA Headquarters
T 714.801.0298
support@acppa.org
www.acppa.org